



# Saskatchewan Guide to Private Well and Water Management



# Audience

This guide is primarily intended to support private well water users in rural Saskatchewan and the management of private wells and source water for the purpose of protecting human health and agriculture in Saskatchewan. This guide also provides useful guidance for small scale regulated water treatment operators, community well users, and First Nations. Private wells used for domestic purposes are found throughout rural Saskatchewan on farms and acreages but also small communities, resort villages and cabins. The guide contains source water protection strategies and well stewardship actions that can be applied to both regulated and unregulated water sources.

For information on industrial water use, licensing, allocation or municipal drinking water regulation, please visit [www.wsask.ca](http://www.wsask.ca) or contact the Water Security Agency.

Water Security Agency  
111 Fairford Street East  
MOOSE JAW SK S6H 7X9

1.866.727.5420  
[client.service@wsask.ca](mailto:client.service@wsask.ca)

Note: several figures in this guide have been adapted from the Well Aware booklet ([www.wellaware.ca](http://www.wellaware.ca)).

# Table of Contents

<b>Chapter 1: Drinking Water Regulations</b>	4
Domestic Water Use	4
Regulated and Unregulated Drinking Water in Saskatchewan	4
Water Use Regulations and Permitting	7
<b>Chapter 2: Saskatchewan Groundwater</b>	8
Characteristics of Groundwater	8
Water Well Development	11
Design and Construction of Private Domestic Wells	11
<b>Chapter 3: Water Quality</b>	18
Drinking Water Guidelines	18
Drinking Water Quality in Saskatchewan	19
Groundwater Wells for Drinking Water	19
Factors Influencing Drinking Water Quality	21
Water Quality Testing	22
Guidelines to Ensuring Safe Drinking Water	24
Preventing and Troubleshooting Aesthetic Water Quality Problems	24
<b>Chapter 4: Source Water Management</b>	27
Source Water Protection	27
Well Maintenance	32
<b>Appendix A – Legislation</b>	33
<b>Appendix B - Example of Water Well Driller Report (WWDR)</b>	35
<b>Appendix C – Shock Chlorination and Disinfection</b>	36
Shock Chlorination – High Level (preferred method)	36
Well Disinfection – Low Level	38
Cistern Disinfection	40
<b>Appendix D – Information and Resources</b>	42
<b>Appendix E - Groundwater Test Suite</b>	43
<b>Appendix F – Well Decommissioning</b>	45
<b>Appendix G – Well Maintenance Schedule</b>	46

# Table of Contents cont.

## List of Tables

Table 1. The risks, regulations and responsibilities for drinking water in Saskatchewan.	5
Table 2. Recommended setback distances for water wells from municipal and non-municipal (private) onsite wastewater systems.	12
Table 3. Planning and choosing a well driller.	17
Table 4. Summary of per cent health and aesthetic drinking water quality exceedances in private wells in Saskatchewan, 1996 to 2011.	20
Table 5. Factors influencing water quality and mitigation to improve safety of drinking water.	22
Table 6. Solution to common household aesthetic water quality problems.	25
Table 7. Setback distances for potential sources of groundwater contamination.	28
Table 8. Well design and construction check-list for well protection.	29
Table 9. Tasks and recommended scheduling for well maintenance.	32

## List of Figures

Figure 1. Aquifers and infiltration rates.	8
Figure 2. Major aquifers in Saskatchewan.	10
Figure 3. Example of good well placement.	12
Figure 4. Large diameter bored well.	14
Figure 5. Small diameter drilled well.	14
Figure 6. Driven point or sand point well.	15
Figure 7. Slotted casing and continuous slot stainless steel screen.	15
Figure 8. Example of a pitless adapter.	16
Figure 9. Water quality testing procedure.	23
Figure 10. Treatment options for aesthetic water quality issues.	26
Figure 11. Well head construction for well protection.	29
Figure 12. Example of a poor water hydrant installation and hose positioning.	30
Figure 13. Surface water contamination from an abandoned well to a well in-use.	31
Figure 14. Completion of typical bored well decommissioning.	31

# Chapter 1: Drinking Water Regulations

## Domestic Water Use

Saskatchewan residents use surface water and groundwater sources for drinking and domestic purposes <sup>1</sup>. Domestic water sources can vary from larger municipally regulated systems to individual private wells. It is important for Saskatchewan residents to understand the level of management or regulation that applies to their water source to determine their level of responsibility in ensuring that their water is safe to drink. Domestic water supplies in Saskatchewan can be identified as:

Water used for domestic purposes includes household and sanitary purposes, the watering of livestock, the spraying of crops and the watering of non-commercial lawns and gardens adjoining private residences, but does not include the sale or barter of water. – *The Water Security Act*

- large municipal waterworks, private public drinking water, or treated water pipelines;
- small private public drinking water, raw water pipelines, or community or municipal wells; and
- private systems (e.g., well, dugout, lake, cistern, bottled or rainwater).

Groundwater plays a significant role in providing safe and sustainable water for people living in Canada. Approximately 3 to 4 million Canadians are dependent on private groundwater wells, with higher dependence in rural locations where suitable surface water sources are not readily available <sup>2,3</sup>. Approximately 43 per cent of Saskatchewan's drinking water is sourced from groundwater including regulated and unregulated wells <sup>3,4</sup>. The Water Security Agency estimates that 18 per cent of rural residents in Saskatchewan consume water from private wells which are also used to sustain their livelihoods.

## Regulated and Unregulated Drinking Water in Saskatchewan

**Regulated drinking water** in Saskatchewan ensures oversight from a regulator that legally enforces safe drinking water standards. Regulations can apply to the training of operators, water quality monitoring, treatment and maintenance of infrastructure associated with the delivery of safe drinking water for public use. Drinking water systems regulated by the Water Security Agency are required to conduct regular water quality monitoring, and the operation and maintenance of the system under the direction of a certified operator as outlined in *The Saskatchewan Water and Wastewater Works Operator Certification Standards* (2016) <sup>5</sup>.

**Multi-Barrier Approach** is 'an integrated system of procedures, processes and tools that collectively prevent or reduce the contamination of drinking water from source to tap to reduce risks to public health'. – Health Canada

Water regulations are enforced by Water Security Agency Environment Officers according to *The Waterworks and Sewage Works Regulations* under *The Environmental Management and Protection Act, 2010*. Regulated water sources pose low risk to human health and include water treatment plants in urban centres and rural municipalities <sup>6</sup>. The Saskatchewan Health Authority similarly enforces drinking water regulation of smaller semi-public systems under *The Health Hazard Regulations*. Water treatment plants serving Saskatchewan's four largest cities (i.e., Saskatoon, Regina, Prince Albert and Moose Jaw) provide regulated drinking water from surface water sources. In rural Saskatchewan, regulated drinking water is predominantly from groundwater sources though surface water use is not uncommon.

All municipal drinking water waterworks are regulated by the Water Security Agency. For treated water pipelines and large communal drinking waterworks, regulation is dependent on the number of houses serviced and volume of treated water the system can provide. Table 1 outlines the regulations, responsibilities and risks associated with drinking water sources in Saskatchewan. For more information about regulated drinking water in Saskatchewan, see the Annual Drinking Water Report at [www.wsask.ca](http://www.wsask.ca). See Appendix A for descriptions and links to relevant acts and regulations.

1 Health Canada. 2019. Be Well Aware – Information for Private Well Owners. <https://www.canada.ca>

2 Lee, D., & Murphy, H. M. (2020). Private Wells and Rural Health: Groundwater Contaminants of Emerging Concern. In Current environmental health reports (vol. 7, Issue 2, pp. 129–139). Springer. <https://doi.org/10.1007/S40572-020-00267-4>

3 Rutherford. 2004. Groundwater use in Canada. Westcoast Environmental Law. Vancouver, British Columbia, Canada. Pg. 32.

4 Statistics Canada. 1996. Groundwater Use in Canada. [www.canada.ca](http://www.canada.ca)

5 Saskatchewan Water and Wastewater Works Operator Certification Standards, December 2016, Edition EPB 539, Water Security Agency

6 For more information on regulated drinking water in Saskatchewan, reference the Water Security Agency's *Annual Reporting on the State of Drinking Water Quality in Saskatchewan* [Water Security Agency Drinking Water Annual Report](http://www.wsask.ca)

**Table 1. The risks, regulations and responsibilities for drinking water in Saskatchewan.**

<b>Drinking Water</b>	<b>Description</b>	<b>Risk</b>	<b>Regulation</b>	<b>Responsibility</b>
<p><b>Municipal Waterworks</b> (all)</p> <p><b>Private Public (Communal) Drinking Water</b> (designed to treat <math>\geq 18</math> m<sup>3</sup>/day)</p> <p><b>Treated Water Pipelines</b> (directly connected to a treated municipal waterworks, those with <math>\geq 15</math> service connections, or designed to treat <math>\geq 18</math> m<sup>3</sup>/day)</p>	<p>Water supplies distributed from a municipal/private water treatment facility. May be ground or surface water sourced.</p>	<p>Multi-barrier approach ensures safe drinking water, which includes source water protection, monitoring, treatment, regulation and distribution of drinking water. Public notifications ensure timely communication of disruptions to the service and quality of drinking water.</p>	<p><i>The Waterworks and Sewage Works Regulations</i></p>	<p>Municipality, operator and the Water Security Agency</p>
<p><b>Private Semi-Public Drinking Water</b> (designed to treat <math>&lt; 18</math> m<sup>3</sup>/day)</p> <p><b>Treated or Raw Limited Scope Water Pipeline</b> (with 3 to 14 service connections)</p>	<p>Water supplies not serviced by a municipal waterworks distribution but are intended for public drinking or personal hygiene.</p>	<p>Due to reduced regulatory monitoring requirements, these systems may be more susceptible to hazards such as pathogenic bacteria and disinfection by-products. Untreated water from pipelines or other sources should not be considered potable. Public notifications ensure timely communication of quality concerns for drinking water.</p>	<p><i>The Health Hazard Regulations</i></p>	<p>Owner and operator of the public water supply and the local Saskatchewan Health Authority or Water Security Agency</p>
<p><b>Private Domestic Drinking Systems</b></p>	<p>Any privately sourced water from private wells, dugouts, lakes, cisterns, bottled water or rainwater used for domestic purposes.</p>	<p>Testing is not required so drinking water quality hazards may not be known and can pose a significant risk to human health. Hazards may include pathogenic bacteria, nitrate and metals. Privately acquired treatment methods may not be effective to ensure drinking water safety.</p>	<p><i>The Ground Water Regulations</i> (apply only to well construction, drilling and evaluation, and decommissioning)</p>	<p>Private well owner</p>

**Unregulated drinking water** sources have no regulatory oversight or requirements to conduct water quality or quantity monitoring, ensure effective treatment, or follow best management practices for source water protection. Unregulated drinking water sources include wells for private or individual use on farms, acreages, lake resorts and small communities or First Nations on individual wells. The protection, maintenance and monitoring of private wells is the responsibility of the well owner. Water quality from unregulated water sources may have significant risks to human health. Other sources of unregulated drinking water include municipal water hauled and stored in private cisterns, surface water (e.g., dugouts), bottled water and rainwater. Reference Chapters 2 and 4 for information and guidance on safe drinking water quality, and how to protect and manage source water.

## Wells

Many Saskatchewan residents use and maintain a **private well** as a domestic water source. In Saskatchewan, private wells for domestic use are not subject to any regulatory oversight and it is the responsibility of the owner to maintain and monitor and treat the water to ensure it is safe to drink. This begins with where and how the well is drilled. *The Ground Water Regulations* provides the standard for well construction in Saskatchewan and well drillers are required to submit Water Well Driller Reports (WWDR) to the Water Security Agency. The well record usually contains information about the characteristics of the well, including well depth, and the quantity of water available for the well's intended purpose. See Appendix B – Example of a WWDR. Water Well Driller Reports can be searched online by using the land location or the driller report number that was provided when the well was completed:

[www.gis.wsask.ca](http://www.gis.wsask.ca)

## Surface Water Dugouts, Lakes, Streams and Rivers

**Surface water** sources and groundwater wells under direct influence (**GUDI**) of surface water may include dugouts, streams, lakes, shallow bored wells (generally less than 100 feet or 30 metres in depth) and wells adjacent to surface water bodies. Shallow wells are sometimes constructed adjacent to surface water sources where deposits of sand, gravel or silty material allow for groundwater recharge or seepage to the well from the surface water source. Use of surface water or GUDI wells without proper treatment increases the potential for pathogens and nitrate to occur in concentrations that exceed drinking water guidelines on an ongoing basis. All surface water and GUDI sources require effective treatment to ensure safe drinking water.

**GUDI** refers to groundwater sources (e.g., wells, springs, infiltration galleries, etc.) where microbial pathogens and organics can travel from nearby surface water to the groundwater source. – Water Security Agency/Ministry of Environment GUDI Assessment Guide EPB 284

## Hauled Water from Municipal Waterworks or Private Public (Communal) Water Sources

Water may be hauled from a nearby municipal waterworks or private public water source (e.g., small community or rural municipality well) and stored in a cistern at a private residence for domestic use. The potential for contamination during hauling and storage from these sources is high and care should be taken to ensure equipment and storage containers are disinfected. To reduce the risk to human health, water should be taken from a potable source and the hauling tank, hoses and storage containers should be regularly cleaned and disinfected. To further reduce risk to human health, a continuous disinfection system within the cistern should be considered. *The Health Hazard Regulations* require that water hauled for public consumption must be hauled from a regulated potable source unless delivered for private use. Trucks hauling water for public or private use are not licensed but may be subject to inspection by the local Health Authority. See Appendix C – Cistern Disinfection.

## Bottled Water

Bottled water sources include commercially purchased bottled water and water bottled from municipal waterworks. Bottled water obtained from a municipal waterworks or purchased from a company may be prone to contamination if the homeowner transfers the water from the original containers prior to use (e.g., fridge containers, water coolers). Regular disinfection of containers used to store water in the home is important. Commercially bottled water is regulated under the Canadian Food and Drug Regulations and should meet the standards set by Health Canada.

## First Nations' Water

Water used for domestic purposes on First Nations is not provincially regulated but is supported by the federal government. Management of water on First Nations may include many partners such as the Chief and Council, Health Canada, Indigenous Services Canada, Tribal Councils and local municipal governments. The Protocol for Centralised Drinking Water Systems in First Nations Communities developed by the Government of Canada is intended to provide First Nations with guidance to establishing drinking water and wastewater services like that of the provincial governments. Water treatment operators on First Nations participate in the First Nations Operator Training Program in Saskatchewan to ensure training and competency of water treatment plant personnel. To learn more about First Nations water management and legislation related to safe drinking water, visit [www.sac-isc.gc.ca](http://www.sac-isc.gc.ca).

## Water Use Regulations and Permitting

The Water Security Agency is the provincial Crown corporation responsible for administering permits and approvals to construct and operate water wells and groundwater works. The agency also issues licences for the right-to-use groundwater. This authority is granted under *The Water Security Agency Act*, *The Water Security Agency Regulations* and *The Ground Water Regulations*. Use of groundwater for industrial or municipal purposes requires the following:

**Industrial water use, for industrial or commercial purposes, is regulated by the Water Security Agency according to *The Water Security Agency Act*.**

A **Permit to Conduct Groundwater Investigation** ensures that proposed developments can be sustained without any adverse impacts on the aquifer or existing groundwater users. It allows for test drilling, well installation and test pumping to evaluate the groundwater source. The proponent is required to provide the Water Security Agency with a Groundwater Investigation Report. The report is then used to support the request for a Water Rights Licence and Approval to Construct and Operate Works. Details on the process and the application for a permit can be found on the Water Security Agency website and payment of a non-refundable fee applies.

A **Water Rights Licence and Approval to Construct and Operate Works** is issued after the groundwater investigation and must be obtained from the Water Security Agency prior to the construction, alteration, extension, or operation of works and water use. Instructions to complete the application are found on the Water Security Agency website and payment of a non-refundable fee applies.

Apply for a [Permit or Licence](#) at [www.wsask.ca](http://www.wsask.ca) or call by phone for more information at 866.727.5420.

See Appendix A - Legislation for more information and links on Acts and Regulations in Saskatchewan.



# Chapter 2: Saskatchewan Groundwater

## Characteristics of Groundwater

**Groundwater** is the water located below ground in the pore spaces within soil, sand and rock (i.e., media). Groundwater is an important part of the **hydrological cycle** which involves the continuous movement of water between the air, land and ocean through several intermediate processes including evaporation, transpiration, condensation, precipitation and runoff. The **water table** is the depth below the surface where the pore spaces between the media are filled with water. Groundwater **recharge** increases the water table in response to water inputs from rain, melting snow, flooding and surface water sources (e.g., lakes, rivers and wetlands). Groundwater **discharge** lowers the water table as water flows to the surface through springs, directly into surface water, or through withdrawal from water wells. Groundwater levels change seasonally depending on recharge, natural discharge, atmospheric pressure and human use (e.g., pumping rate).

The rate of groundwater recharge can increase water table levels from less than 5 mm to 40 mm per year depending on the climatic and geologic conditions.

Aquitards commonly consist of glacial till. Glacial till is an unsorted geologic layer consisting mainly of clay with some sand, silt and boulders deposited directly by glaciers. Aquitards are also commonly formed by clay and shale deposits. They do not allow water to flow very easily.

**Aquifers** are geologic layers, within which, water flows easily, providing the flow required to supply water to a well (Figure 1). In Saskatchewan, most aquifers are made up of sand and gravel. An **aquitard** is a geologic layer commonly made of till, shale or clay that forms a barrier to water flow. In Saskatchewan, aquitards generally do not provide enough water supply for a well but can act as a barrier to surface water contamination into aquifers. A **confined aquifer** is an aquifer that is located between two aquitards (above and below). In a confined aquifer, the water levels in a well usually rise above the top of the aquifer because the water is under pressure and is often called an **artesian well**.

An aquifer whose upper boundary is defined by the water table, rather than an overlying aquitard, is called an **unconfined** aquifer. Groundwater levels in unconfined aquifers are largely dependent on recharge from the surface, which makes them more responsive to seasonal changes and more susceptible to surface water contamination than confined aquifers.

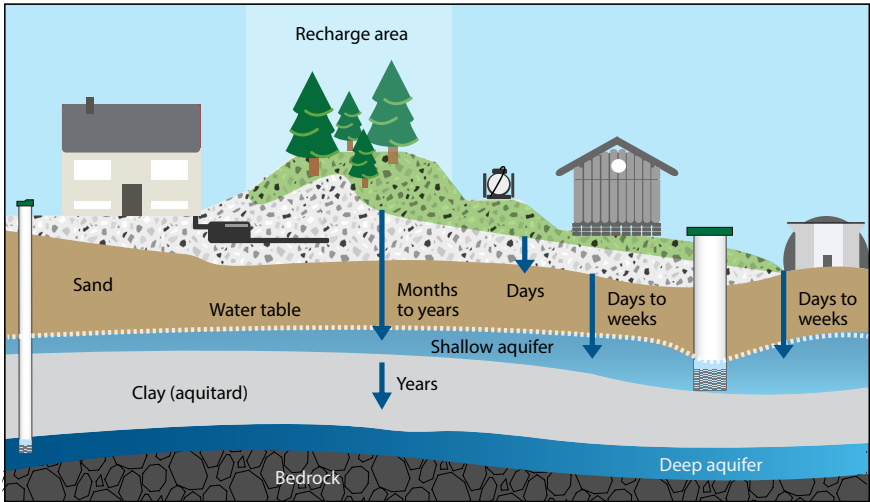

Figure 1. Aquifers and infiltration rates.

Saskatchewan aquifers are described by the geological formation in which they are found. They fall into two general categories based on how they were formed. These two categories are bedrock and glacial drift aquifers (Figure 2).

You may think that bedrock formations in southern Saskatchewan are made of hard rock. Not so - these formations are made of clays, silts, fine sands and sandstones.

In Saskatchewan, glacial drift deposits are less than 2.6 million years old and were formed during the Quaternary Period in geologic time. The last glacial retreat in the Regina area took place approximately 12,000 years ago.

**Bedrock aquifers** are large and generally consist of fine to very fine-grained sand. The fine-grained sand forming these aquifers can reduce groundwater supply or yield, limiting their use for large industrial and municipal use. Bedrock aquifers are important groundwater sources in west central, southwest, and the lower southeast parts of the province and include the Judith River, Eastend, Frenchman and Ravenscrag formations.

**Glacial drift aquifers** were deposited during a period of glaciation. Glacial drift consists mainly of glacial till but also includes sand and gravel layers. The glaciers and their meltwater shaped the present-day land surface and left behind till deposits up to 200 m thick in Saskatchewan. Glacial drift aquifers within the till deposits vary in size and water quality leading to a range in supply that can support large scale industrial or municipal requirements or be limited to small scale facilities and private domestic use.

Glacial drift aquifers are the most common groundwater source in Saskatchewan and include buried valley aquifers, blanket aquifers, intertill aquifers and surficial aquifers.

**Buried valley aquifers** are found in river valleys that were formed prior to the Quaternary Period. Composed of sand and gravel, these valleys were buried by glacial deposits through glaciation. Buried valley aquifers can provide high water supply to wells. Three major buried valley aquifers in Saskatchewan are the Hatfield Valley, Tyner Valley and Estevan Valley aquifers.

**Blanket aquifers** are formed by large sand and gravel deposits. Three major blanket aquifers in Saskatchewan are the Pathlow, Meacham and Wynyard-Melville aquifers.

**Intertill aquifers** are the most common aquifers in southern Saskatchewan and provide most of the groundwater in and around Regina and Saskatoon. Intertill aquifers vary in size, thickness, water quality and productivity, and are composed of gravels, sands and silts between layers of glacial till.

**Surficial aquifers** are typically unconfined aquifers that are close to the surface (shallow) and more directly affected by climate variations such as drought, high rainfall and snowmelt. They are located throughout Saskatchewan and vary in size and productivity but provide some of the best quality groundwater. Surficial aquifers are often ideal for domestic use but are also more susceptible to contamination than other types of aquifers, making source water protection a priority.

The Hatfield Valley Aquifer is the largest buried valley aquifer in Saskatchewan. It crosses the province and extends up to 30 km wide and up to 100 m thick.

The City of Yorkton is the largest community in Saskatchewan to rely on groundwater, accessing water from several intertill aquifers.

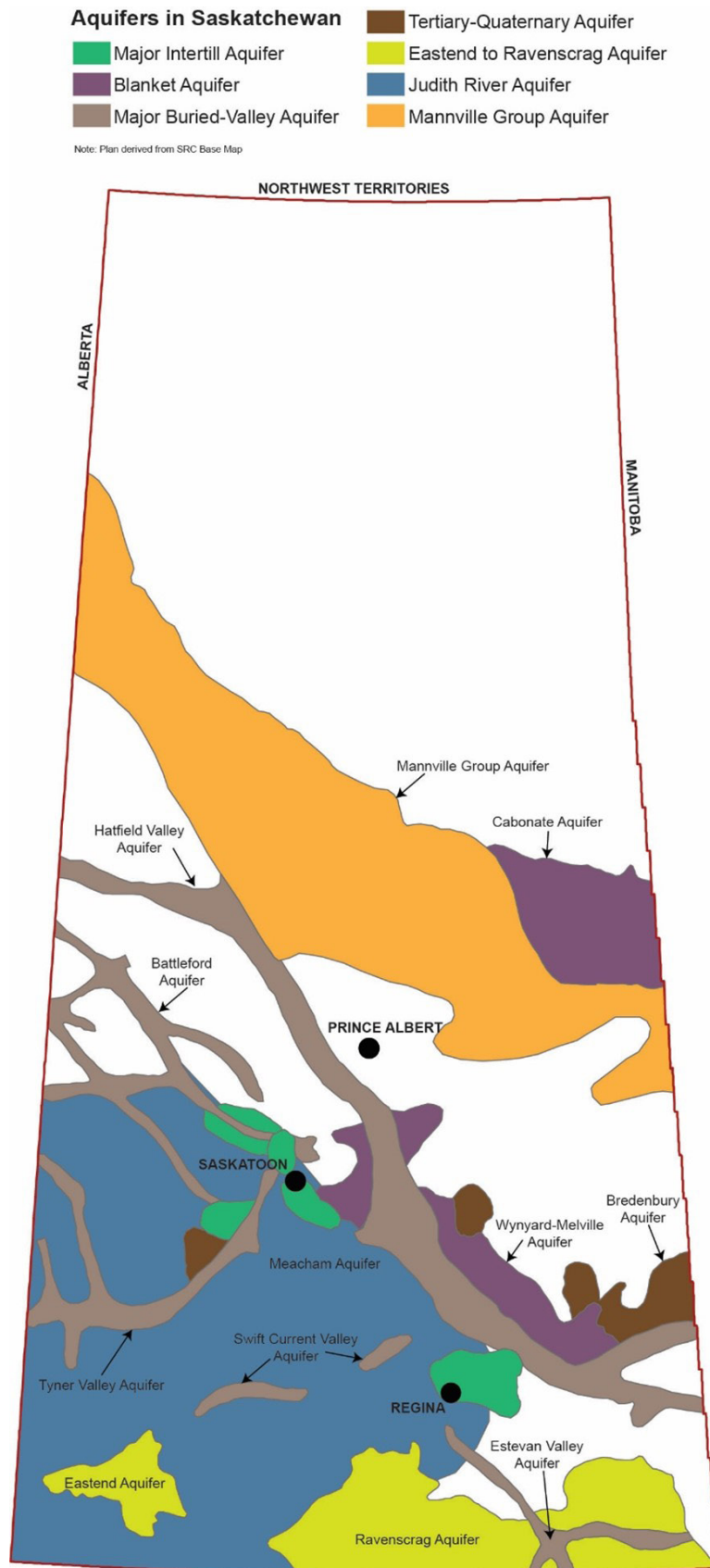

Figure 2. Major aquifers in Saskatchewan.

## Water Well Development

Drilling a water well is an important activity and requires good planning to ensure a safe and sustainable water source for your home, farm, business, municipality or industry. It is important to note that, although there is a process in place, there are always unique circumstances and requirements associated with establishing a water well. If the well is being constructed for any purpose, with exception of private domestic use, then contact the Water Security Agency at [www.wsask.ca](http://www.wsask.ca) and do not begin the construction of a groundwater development project before receiving a Permit to Conduct Groundwater Investigation or Approval to Construct (See Chapter 1 – Water Use Regulations and Permitting).

### Design and Construction of Private Domestic Wells

Water well construction requires planning. The following information can be used as a general guide for private domestic wells to ensure that the well meets expectations.

#### 1. Groundwater Source and Well Location

Most private well owners work with their well driller to determine the site-specific location for a well and approximate depth of the aquifer on their property. The Water Security Agency can also provide groundwater information to the public or well drillers. Factors to consider when planning a well include: <sup>7</sup>

When calling the Water Security Agency for groundwater information, ensure that you have your land location available.

- Natural features – avoid areas with potential for surface water runoff or pooling
- Potential sources of contamination – avoid areas with wastewater systems, other wells, fuel/oil/fertilizer/chemical storage, cleaning products, livestock yards and barns, etc.
- Safety – consider the presence of overhead power lines, buried utilities or traffic
- Access – for monitoring and maintenance purposes, the well should always be accessible

Wells should be located away from areas of potential contamination sources and flood-prone areas. Landscaping and sloping around the well casing to divert surface water runoff away from the well can decrease risk of contamination. The Water Security Agency recommends following the setback distances provided in the *Guidelines on Land Application of Municipal Biosolids WSA 522* and *The Waterworks and Sewage Works Regulations*. Municipal sewage works are usually situated as far as possible from potable water wells and groundwater monitoring may be required according to the *Sewage Works Design Standards EPB 503*. Private onsite wastewater setback distances from drinking water wells are also discussed in the *Saskatchewan Onsite Wastewater Disposal Guide* <sup>8</sup>.

See Chapter 4 – Source Water Management for setbacks to other sources of contamination. An example of private well placement on a rural property is provided in Figure 3.

Attempts should be made to maximize the distance between wells and sources of contamination, especially in shallow sand aquifers.

<sup>7</sup> Green Communities Canada. Well Aware booklet, A Guide to caring for your well. [www.greencommunitiescanada.org](http://www.greencommunitiescanada.org)

<sup>8</sup> Government of Saskatchewan. Saskatchewan Onsite Wastewater Disposal Guide. [www.publications.saskatchewan.ca](http://www.publications.saskatchewan.ca)

**Table 2. Recommended setback distances for water wells from municipal and non-municipal (private) onsite wastewater systems.**

Onsite Wastewater System	Private or Non-municipal Minimum Setback (< 18 m <sup>3</sup> /day wastewater discharge)	Municipal Minimum Setback (≥ 18 m <sup>3</sup> /day wastewater discharge)
Liquid domestic waste (septic) disposal	200 m to any well	200 m to any well
Septic or holding tank	9 m to any well	9 m to any well
Absorption field, mound or subsurface disposal	90 to 200 m depending on the slope to any well	90 to 200 m depending on the slope to any well
Jet septic	90 to 200 m depending on the slope to any well	90 to 200 m depending on the slope to any well
Lagoon or mechanical sewage treatment	500 m to any well	500 m to any well

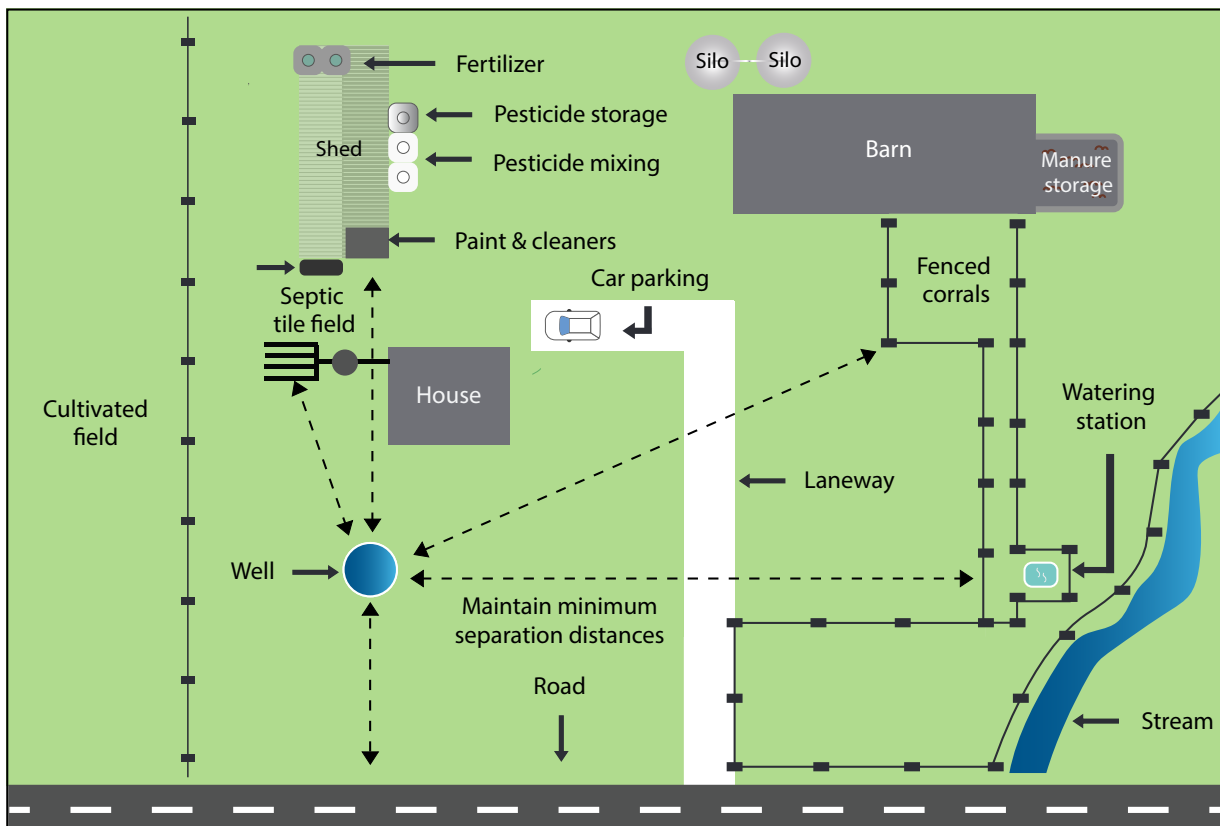

*Figure 3. Example of good well placement where the well owner ensured a minimum separation distance is maintained and contamination risks are minimized or eliminated.*

## 2. Water Requirements

Estimating the average water demand and potential peak demand is based on water usage. To ensure a reliable water source, discuss your water requirements with the well driller who can then determine if the aquifer can meet long-term demands. For example, domestic well users will require much less water than those with livestock operations. In 2021, the average Canadian used approximately 223 litres of water per day for consumption and household use<sup>9</sup>, whereas a livestock producer with 200 head of cows and no calves could require over 10,000 litres of water per day!

The following resources can be used to determine the water requirements (use) of a groundwater well:

### Household Use

The Water Security Agency annually provides water consumption data for most Saskatchewan municipalities. Saskatchewan residents use an average of 332 litres of water per person per day. The Water Security Agency recommends that wells meet a minimum of 350 litres per person, per day for household use.

### Livestock Watering

Livestock watering is variable depending on the type and number of animals, the weather and water quality. To ensure livestock watering needs will be met, reference the *Livestock Water Quality – A Field Guide for Cattle, Horses, Poultry, and Swine*<sup>10</sup> and contact the Saskatchewan Ministry of Agriculture Knowledge Centre (1.866.457.2377) to confirm daily requirements of your livestock operation.

### Municipal Systems

Approval to construct, extend or alter any municipal waterworks must be obtained from the Water Security Agency prior to construction. The requirement for approval falls under Section 24 of *The Environmental Management and Protection Act, 2010*. Systems that typically require approval include water treatment facilities, water distribution systems and water pumping stations. Information on the application process and design requirements, which includes the determination of water requirements and additional approvals, is found in the *Waterworks Design Standard EPB 501* document located at [www.publications.saskatchewan.ca](http://www.publications.saskatchewan.ca) or by contacting the Water Security Agency.

**Hand dug** wells with wooden casings were common on the prairies in the early to mid-20<sup>th</sup> century but are no longer common practice.

Reminder: a domestic use water well with a distribution system serving 3 or more services is regulated according to *The Health Hazard Regulations* or *The Waterworks and Sewage Works Regulations*, depending on the number of service connections and design capacity.

## 3. Well Design

Well design considers the well depth, type and size of well casing, well screen, intake design and seal of the annulus (the space between the well casing and the aquifer formation). The well design is based on the aquifer characteristics and water requirements determined by drilling a **test hole**. The two main types of wells in Saskatchewan are bored and drilled wells.

After a test hole has been completed, the well driller may complete a **geophysical log (e-log)** that includes the physical and chemical properties of the geological formations to identify the aquifer and to determine the best depth at which to set the screen for optimal water production.

<sup>9</sup> Statistics Canada. 2021. Survey of Drinking Water Plants, 2021. [www150.statcan.gc.ca](http://www150.statcan.gc.ca) (accessed 20-Dec-2023)

<sup>10</sup> Olkowski, A.A. 2009. *Livestock Water Quality: A Field Guide for Cattle, Horses, Poultry and Swine*. Agriculture and Agri-Food Canada.

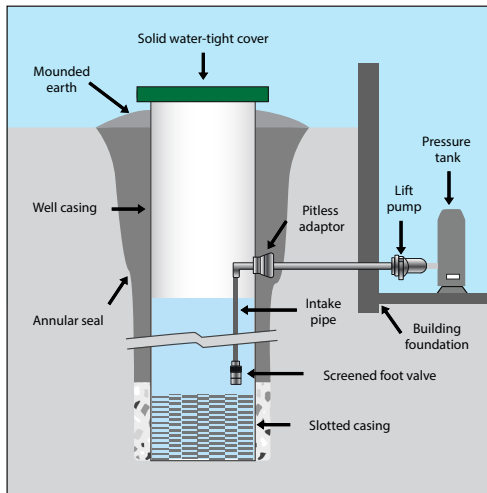

**Bored wells**, or large diameter wells, are created using a rotary bucket rig, which bores a hole approximately 42 inches (107 centimetres) in diameter and requires a well casing of approximately 30 to 36 inches (76 to 92 centimetres; Figure 4). Well casings may be made of corrugated galvanized steel, or fiberglass. Today, most bored wells are constructed with fiberglass casing, which has slots or perforations cut into it to allow water to flow into the well. On the outside of the well casing, there is a space between the borehole wall and the casing called the **annular space**. Washed gravel or frac sand is packed around the casing slots or perforations to filter out the aquifer material and allow more efficient flow into the well. This is referred to as the sand pack.

**Frac sand is high purity quartz sand that is uniform in grain size and composition.**

Figure 4. Large diameter bored well.

The sand pack allows for a more efficient well and aides in keeping fine materials from entering the well. The space above the slotted portion of the casing (**annular seal**) should be filled with concrete or grout to prevent contamination into the aquifer.

Bored wells are usually less than 100 feet (30.5 metres) in depth and are often constructed in aquifers high in silts and fine sand with limited production capacity. In these cases, the large diameter casing acts as a storage reservoir to meet peak demand. Due to the shallow depth of bored wells, they tend to be more susceptible to drought and flooding than deeper wells so water levels should be monitored over time. Their shallow depth also increases the potential for contamination, which means best land-use practices, well maintenance and water quality testing are very important to maintaining them as safe drinking water sources.

**Drilled wells**, or small diameter wells, are made using a rotary drilling rig, which uses a drill bit and circulating drilling mud (Figure 5). Well casings are generally four to six inches (10 to 15 centimetres) in diameter and can be made of steel or plastic with a stainless-steel screen at the bottom within the water bearing zone. A larger casing may be used to accommodate a larger pump for higher volumes of water. The annular space along the casing, with exception of the bottom where the well screen is located, should be sealed with a bentonite grout and cement mixture to prevent surface water contamination into the aquifer. Like bored wells, the annulus adjacent to the well screen is filled with a sand pack.

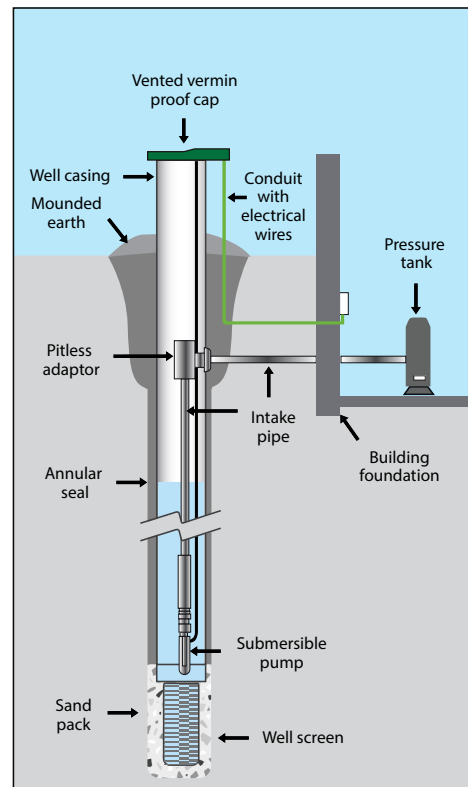

Figure 5. Small diameter drilled well.

Drilled wells can be over 1,000 feet (305 metres) deep. Drilled wells are less responsive to drought and less prone to contamination than bored wells, but they still benefit from best land-use practices, well maintenance and water quality testing.

**Flowing artesian wells** require the driller to set in a cement surface casing to control the flow of water as outlined in the *Saskatchewan Ground Water Regulations*. Flowing artesian wells can flow out of the casing onto the ground at rates that range from a trickle to volumes that can cause localized flooding if the well is not properly constructed. Well drillers and well owners may be liable for property damages resulting from uncontrolled flowing wells according to *The Water Security Agency Act and Regulations*.

**Sand point wells** are small diameter wells that are created using water to jet the casing and screen assembly down into a surficial aquifer. Sand point wells may also be driven into the aquifer. These types of shallow wells are less than 50 feet (15 metres) in depth (Figure 6). Driven wells, or sand points, are not very common in Saskatchewan and pose an increased risk of contamination from surface water during flooding and from land-use activities such as manure storage.

The **well screen** is a critical component of a water well. The openings or slots in a screen must be large enough and adequate in number to allow a sufficient volume of water into the well. At the same time, the slots must prevent sand and fine aquifer material from entering the well. Screen slot size depends on the size of the aquifer material. **Slotted** casing screens may be pre-made or slotted on site, while **continuous slot stainless steel** screens are pre-made and come in a variety of diameters and sizes (Figure 7).

Continuous slot stainless steel screens are commonly used in drilled wells but are often too expensive for use on a large diameter bored well. A slotted casing is usually used for bored wells, though it is less efficient than a continuous slot stainless steel screen. Water flow through a continuous slot stainless steel screen is more efficient than through a slotted casing and allows for more effective development, treatment and maintenance of the well.

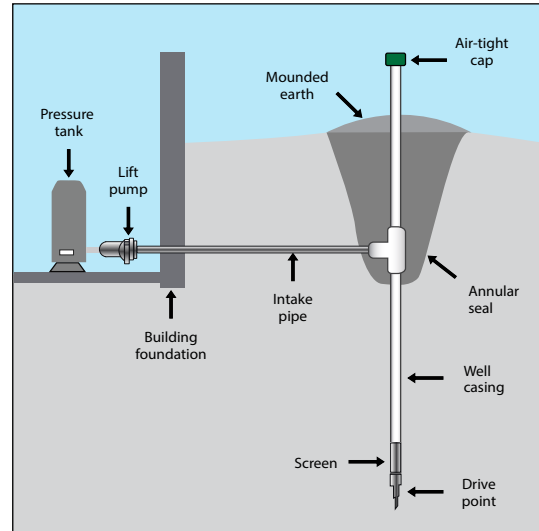

Figure 6. Driven point or sand point well.

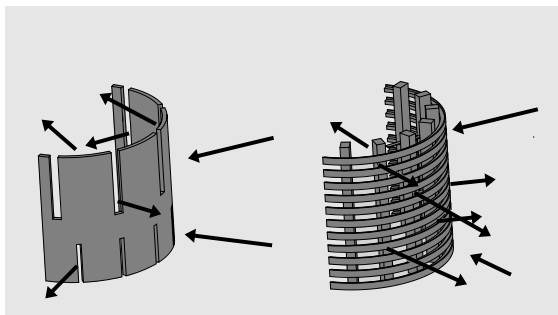

Figure 7. Slotted casing and continuous slot stainless steel screen.

**Well caps** on drilled wells are made of steel or plastic with a rubber gasket to prevent surface water, vermin and insects from entering the well. Well caps on drilled wells must be vented to equalize the pressure inside the well to the outside. Well caps on bored wells are made of galvanized steel or fiberglass. The seal on a bored well cap is not as tight as on a drilled well but they will keep vermin and insects out if maintained to ensure there are no cracks or holes. Caps should be sealed or friction fit and locked for safety and to prevent vandalism.

**Work with your driller and the Water Security Agency to gather well information to:**

- estimate the potential yield for the well;
- estimate water quality for the intended water use;
- determine options for well design; and
- gather any other relevant information associated with wells in the area.

A **pressure tank** is a pre-charged air tank that compensates for the pressure changes of a pump that cycles on and off.

**Well pumps** are an important part of the distribution system and are required to move water out of the well and into the distribution system. **Submersible** pumps are common and are sized to match the water requirements. Traditionally, submersible pumps are connected to a pressure switch and tank, but constant pressure pumps, which dispense without the need for a pressure tank, are becoming more commonly used. Alternatively, a jet pump can be installed near the pressure tank inside the home with a foot valve to ensure that the pump maintains prime.



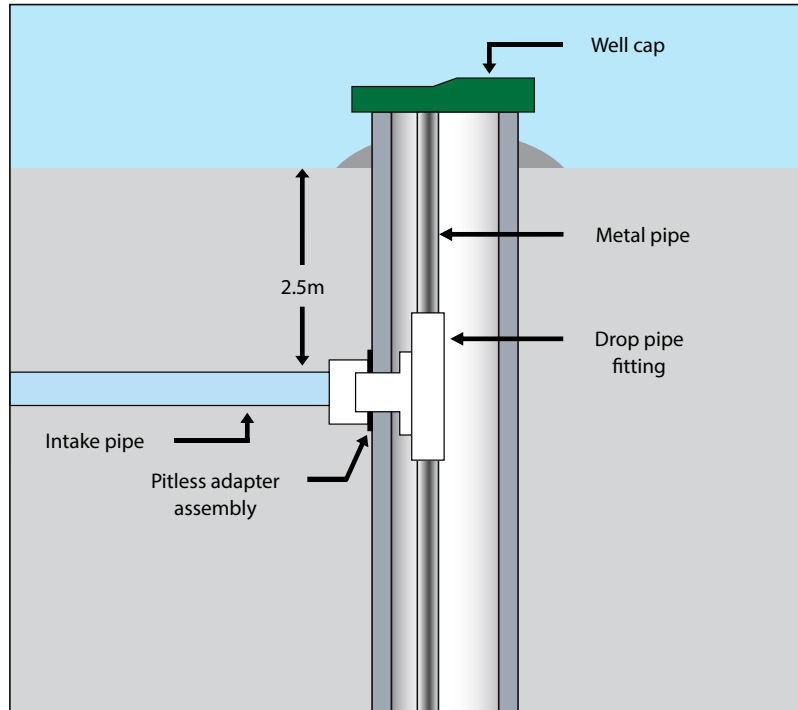

Figure 8. Example of a pitless adapter.

A **pitless adapter** is a two-piece brass assembly that connects the well to the distribution system at a point on the well casing below the frost line (Figure 8). To install a pitless adapter, a section of the casing is cut out and the outer saddle of the assembly is clamped to the exterior of the casing. The water pump is then installed in the well and connected to the second brass piece on the interior of the casing, which is then connected to the piece of the assembly. Pitless adapters are necessary to eliminate the use of well pits, which pose a risk to human health (see Chapter 4 – Source Water Management).

#### 4. Well Development

After the well casing, screen, gravel pack and annular seal are in place, the well driller must develop the well. **Well development** is the process of removing fine sediment and drilling mud from the aquifer around the well screen to maximize flow from the aquifer into the well. The driller may use a combination of pumping, surging and jetting water through the well screen to clear it. Jetting is most effective when trying to clear continuous stainless-steel slot screens.

Once the well is developed, the driller will conduct a **yield test** by pumping the well and measuring the water level decline to determine the depth that the pump should be placed and the pumping rate for the well. Repeating the yield test in the future can identify changes in well performance and the need for well repairs or maintenance. The driller will complete the well installation by **disinfecting** the well. If the pump installation takes place later, the well owner will need to disinfect again before using the well.

#### 5. Choosing a Well Driller

In Saskatchewan, well drilling rigs are registered according to *The Ground Water Regulations*. It is best to use a local driller with knowledge of the local geology where the well is to be constructed. Table 3 provides guidance for planning and choosing a well driller. A current list of [registered drilling rigs](#) can be found on the Water Security Agency website.

Provincial Water Well Driller Reports (WWDR) may also be accessed online through the Water Security Agency's [Water Well Information Database](#).

**Table 3. Planning and choosing a well driller.**

<b>Landowner Homework</b>
Is this a replacement well? <input type="checkbox"/> YES <input type="checkbox"/> NO
If YES, was the water quality and quantity satisfactory?
If YES, what was the depth, diameter, casing material, and well use?
If YES, is there a water well driller report and a geophysical log (e-log) for the well or test holes?
Do you want to find another aquifer for your new well? <input type="checkbox"/> YES <input type="checkbox"/> NO
If YES, contact Groundwater Services in the Water Security Agency to determine:
1) potential aquifers
2) most appropriate method to explore or develop a well
3) thickness of the aquifer or water bearing zone
4) potential yield from the aquifer
5) general water chemistry
<i>Based on the above, do you have the yield and water quality that will result in a sustainable water source for your purposes?</i> <input type="checkbox"/> YES <input type="checkbox"/> NO
<b>Well Driller Information</b>
Is the well driller registered with the Water Security Agency? <input type="checkbox"/> YES <input type="checkbox"/> NO
Do they have references that can be contacted? <input type="checkbox"/> YES <input type="checkbox"/> NO
Do they provide written agreement and warranty on the work? <input type="checkbox"/> YES <input type="checkbox"/> NO
Can they describe how they complete wells as it relates specifically to geology in the area? <input type="checkbox"/> YES <input type="checkbox"/> NO
What would they suggest for well design, construction and pumping equipment? Is this in line with information collected from the Water Security Agency and other landowners in the area? <input type="checkbox"/> YES <input type="checkbox"/> NO
Do they e-log test holes? <input type="checkbox"/> YES <input type="checkbox"/> NO
What is the cost per foot for the test hole?
Do they decommission test holes? <input type="checkbox"/> YES <input type="checkbox"/> NO
What is the cost per foot for the well?
What is included in their quote (e.g., test hole, well, materials, sizing of pump, disinfection, etc.)?

**Responsibilities of Well Owners and Operators**

For a list of regulations and responsibilities of owners and operators see Chapter 1 – Table 1. Chapter 4 – Source Water Management provides information on best land use practices, well maintenance and groundwater protection for sustainable and safe water use.

# Chapter 3: Water Quality

Effective water management requires an understanding of the quality and characteristics of the water for its intended purposes. **Water quality** can be defined by the chemical, physical, biological or radiological condition of the water. Surface and groundwater quality throughout Saskatchewan is highly variable depending on the source. Water quality monitoring depends on the intended water use and dictates the type of testing. Although drinking water is a primary public health concern, water quality can also impact the health of animals and aquatic life, as well as agricultural production in Saskatchewan. The province provides water quality guidelines for the following water uses:

- Drinking Water <sup>11</sup> – used for human consumption or hygiene (e.g., domestic non-consumptive use)
- Irrigation and Agriculture <sup>12</sup> – used for watering, spraying, or facilitating crop production
- Livestock <sup>13</sup> – used to water livestock
- Recreation <sup>12</sup> – used for human activities on or in water (e.g., swimming, boating, etc.)
- Aquatic Life <sup>12</sup> – surface water that provides important habitat for aquatic species (e.g., fish, invertebrates, etc.)

Drinking water should be tested by a laboratory accredited by the Standards Council of Canada. These laboratories are accredited to ISO 17025:2017, which can be found on the Canadian Association for Laboratory Accreditation website (see Appendix D – Information and Resources for links to these websites). A list of accredited labs in Saskatchewan can be found at: [CALA Directory of Laboratories](#). Water quality testing carried out by non-accredited laboratories should not be relied upon where potential risk could have serious consequences (e.g., drinking water).

The following sections focus on the use of water for human consumption and how to identify and decrease potential health risks. Relative human health risks associated with regulated and unregulated water supplies are summarized in Chapter 1 – Table 1. Chapter 4 provides information to ensure source water protection to decrease potential for groundwater contamination and therefore risks to human health and livestock.

## Drinking Water Guidelines

In Canada, the *Guidelines for Canadian Drinking Water Quality* are developed by the Federal-Provincial-Territorial Committee on Drinking Water. In addition to protecting human health, the guideline values are selected based on the treatability of the water, availability of technologies to measure and remove contaminants, and to improve the aesthetic quality of the water. Drinking water quality guidelines fall into three categories:

**Maximum Acceptable Concentration (MAC)** – these guidelines are established for water quality parameters that are known or suspected to cause adverse health effects. Each MAC has been derived using current scientific information to safeguard human health. Water quality parameters higher than the MAC can pose a risk to human health. Water treatment must be used to lower the contaminant levels in drinking water in order to reduce the health risk.

Water quality guidelines for recreation and aquatic life are published in the [Saskatchewan Surface Water Quality Objectives](#).

<sup>11</sup> Water Security Agency. Saskatchewan's Drinking Water Quality Standards and Objectives (Summarized). EPB 507. [Publications Centre \(saskatchewan.ca\)](#)

<sup>12</sup> Water Security Agency. Surface Water Quality Objectives, Interim Edition. EPB 356. [Publications Centre \(saskatchewan.ca\)](#)

<sup>13</sup> Contact Agriculture Knowledge Centre in Moose Jaw 1.866.457.2377

**Interim Maximum Acceptable Concentration (IMAC)** – these guidelines are established for water quality parameters that have insufficient scientific information to derive a MAC. The IMAC acknowledges the water quality parameter is a potential health risk and well water containing concentrations higher than an IMAC should be treated like a MAC. This means that treatment must be used to lower the contaminant levels in the water prior to consumption.

**Aesthetic Objective (AO)** - these guidelines are established for water quality parameters to ensure the water has an acceptable taste, smell, colour and function. These parameters are not known to cause any adverse health effects, but they can make the water less desirable or unusable within the home (e.g., corrosion of taps and fixtures, and staining of bathtubs, sinks and laundry).

Saskatchewan uses the federal guidelines to select the provincial drinking water quality standards and objectives. *Saskatchewan's Drinking Water Quality Standards and Objectives* are published by the Water Security Agency and are applied to water used for domestic purposes. Regulated drinking water must meet drinking water **standards** to provide greater assurance of safe drinking water to the public. Standards are legally enforceable requirements for drinking water quality and as set out in *The Waterworks and Sewage Regulations*. **Objectives** apply to water quality parameters that affect the aesthetics or functionality of the water but do not pose a risk to human health. For unregulated systems (i.e., private water supplies) these values can be used to support safe drinking water but are not legally enforceable. Landowners using private water supplies are responsible for the costs and activities associated with water quality monitoring and the effectiveness of treatment.

## Drinking Water Quality in Saskatchewan

### Regulated Drinking Water

Regulated drinking waterworks facilities in Saskatchewan provide safe drinking water throughout the province. Human health risks associated with consumption of water from regulated systems in Saskatchewan is very low. The Water Security Agency publishes an Annual Drinking Water Report that reports high compliance and satisfaction with regulated drinking water throughout the province<sup>14</sup>. Regulated systems include municipalities, pipelines and large commercial water systems. Regular monitoring, water treatment, education and reporting are carried out to ensure a high level of public confidence in the safety of drinking water.

### Unregulated Drinking Water

Unregulated drinking water includes community wells and raw water pipelines marked as non-potable, as well as private water sources used for domestic purposes. Individuals consuming unregulated water should consider protecting source water from contamination, monitoring the water quality, and mitigating the human health risks associated with consumption through effective water treatment. Individuals choosing to consume unregulated water do so at their own risk and are responsible for the management of those risks.

### Groundwater Wells for Drinking Water

Groundwater in Saskatchewan commonly exceeds at least one drinking guideline for nitrate, bacteria and trace metals (e.g., arsenic, uranium, manganese and selenium; Table 4). In Saskatchewan, 87 per cent of private wells exceed at least one health drinking water quality guideline while 93 per cent exceed at least one health or aesthetic objective<sup>15</sup>.

---

<sup>14</sup> Water Security Agency. Drinking Water Annual Report. [www.wsask.ca](http://www.wsask.ca)

<sup>15</sup> Water Security Agency. 2020. Summary of statistics from the Rural Water Quality Advisory Program.

**Table 4. Summary of per cent health and aesthetic drinking water quality exceedances in private wells in Saskatchewan, 1996 to 2011<sup>15</sup>.**

Parameter (units)	No. Records	Objective†	No. Exceedances	Per cent Exceedances
<b>Health Parameters</b>				
Arsenic (ug/L)	4164	10	586	14
Escherichia coli (MPN/100mL)	1468	0	83	6
Fluoride (mg/L)	2154	1.5	30	1
Lead (mg/L)	4164	0.01	30	1
Manganese (mg/L)	4178	0.12	2427	58
Nitrate (mg/L)	4470	45	574	13
Selenium (mg/L)	4158	0.01	480	12
Total Coliform Bacteria (MPN/100mL)	4260	0	1618	38
Uranium (ug/L)	4158	20	798	19
<b>Aesthetic Parameters</b>				
Chloride (mg/L)	4106	250	216	5
Iron (mg/L)	4178	0.3	2073	50
Magnesium (mg/L)	4105	200	254	6
Manganese (mg/L)	4178	0.05	2859	68
Sodium (mg/L)	4105	300	853	21
Sulfate (mg/L)	4105	500	1619	39
Sum of Ions (mg/L)	4105	1500	1766	43
Total Hardness (mg/L)	4105	800	1269	31

†Saskatchewan's Drinking Water Quality Standards and Objectives; health objective for manganese from Health Canada's Canadian Drinking Water Guidelines

This means that groundwater in Saskatchewan should be tested and monitored when used for domestic purposes. Many laboratories have potability tests (e.g., chemical health and toxicity testing), including nitrate and bacteria. Initial testing or testing prior to treatment installation should include:

**Nitrate** – Nitrate is one of the most common groundwater contaminants in rural areas. It occurs naturally in soil and water because of decaying plants and animal residues. Other sources of nitrate include human sewage, livestock manure and fertilizers. Nitrate is highly soluble and moves easily with water through soil. High concentrations of nitrate are a health concern for anyone consuming the water; however, young infants and pregnant women are at particular risk.

**Bacteria** (*Escherichia coli* and total Coliform bacteria) – Coliform bacteria can occur naturally in the environment or from fecal sources. Not all coliform bacteria are harmful; however, their presence suggests disease-causing organisms (pathogens) may be present (i.e., *E.coli* 0157:H7). The presence of coliform bacteria or *E.coli* requires disinfection and treatment. Treatment systems should have the National Sanitation Foundation certification for microbiological removal (NSF Standard 55 Class A for disinfection units, NSF Standard 62 for distillation units).

**Major Ions** – Major ions are the main chemical constituents of natural water and are made up of positive and negative ions that contribute to the hardness and total dissolved solids content and include bicarbonate, calcium, carbonate, chlorides, magnesium, potassium, sodium and sulphate.

**Trace Metals** – Concentrations of manganese, arsenic, selenium and uranium are metals found in Saskatchewan groundwater. Metals are naturally occurring in groundwater but concentrations greater than drinking guidelines can pose a potential health risk. Metals such as lead and copper may be detected as a result of the distribution pipes especially under conditions of low pH, which can occur after some types of household treatment (e.g., reverse osmosis). Saskatchewan groundwater is naturally high in iron which is an aesthetic problem but does not pose a human health risk.

For the complete list of test parameters for groundwater see Appendix E – Groundwater Test Suite.

Use of surface water from dugouts, streams or rain collection is not recommended for human consumption without effective treatment. Surface water has additional risks associated with toxic algae blooms and parasites, including *Cryptosporidium* and *Giardia*. Groundwater with surface water infiltration (i.e., GUDI) or flooding may pose health risks similar to surface water sources.

## Factors Influencing Drinking Water Quality

Once you have tested your water source and understand the results, it is important to consider other factors that influence the water prior to use including distribution, storage, treatment and land use. For example, hauling water from a treated municipal source and storing it in a cistern can result in contamination during transport or storage. Table 5 identifies some factors that can influence your source water quality and how to mitigate the potential for contamination.

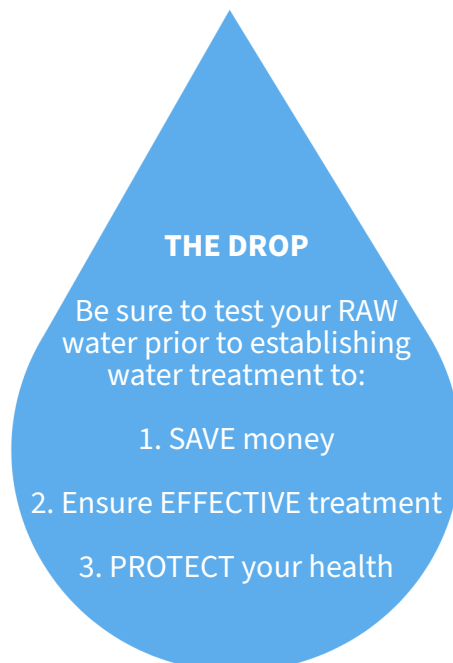

**Table 5. Factors influencing water quality and mitigation to improve safety of drinking water.**

<b>Factor</b>	<b>Problem</b>	<b>Solution</b>
Water Distribution	High concentrations of copper or lead.	Flush lines before using the water for human consumption (confirm flushing reduces the concentrations of copper or lead through testing). Install effective treatment that is not contributing to physical water quality conditions that increase the release of metals from the distribution system.
	Presence of coliform bacteria.	Conduct regular shock chlorination of the well and distribution system. Install effective disinfection or treatment to eliminate the source of bacterial contamination to the distribution system.
Storage	Presence of coliform bacteria.	Regular shock chlorination and cleaning of storage containers followed by sufficient treatment. Install effective disinfection through chlorination or ultraviolet.
Treatment	Water treatment may change the physical characteristics of the water (e.g., pH, oxygen, temperature), which may result in release of metals. Poorly maintained equipment may not effectively treat the water for drinking and can harbour bacteria and result in a build-up of metals. Softeners may increase the sodium in the water making it not suitable for drinking.	<p>Have a schedule for system maintenance and keep a log identifying the date and type of work done on the system.</p> <p>Periodically test post-treatment to confirm treatment is effective.</p> <p>Ensure water treatment and conditioning of the water is appropriate and is not leading to additional potential health concerns.</p>
Land Use	Land use activities and poor well construction/maintenance can be a source of contamination to source water.	See Chapter 4: Source Water Management.

## Water Quality Testing

The only way to know if your water poses risks to human or animal health is to test the water regularly (Figure 9). A well used for human consumption should be tested at least two to three times per year. Additional testing should be conducted for nitrate and bacteria after spring runoff, heavy rains or if a change in water quality is detected within the home.

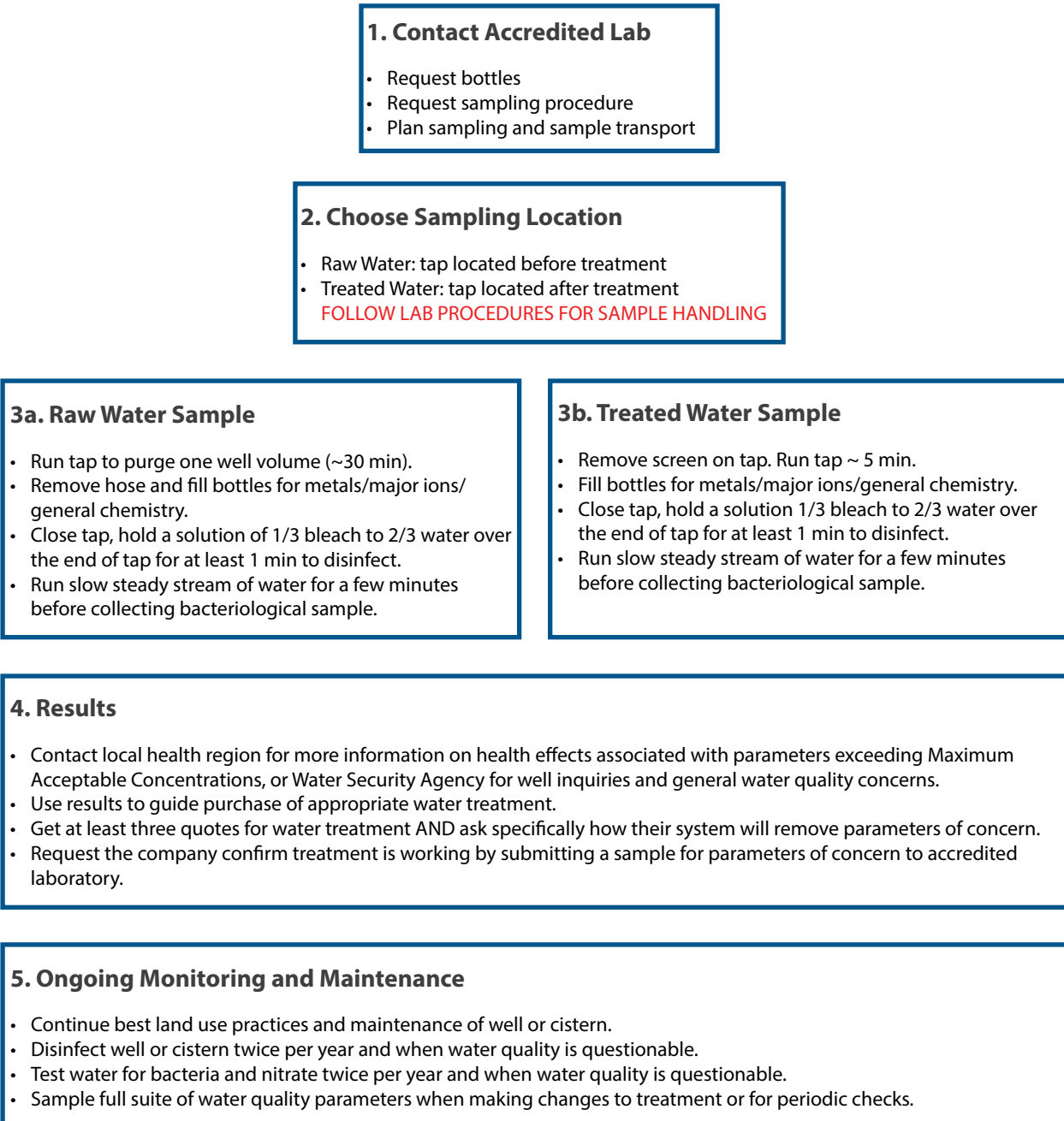

Figure 9. Water quality testing procedure.



## Guidelines to Ensuring Safe Drinking Water

- 1. TEST** – Raw water should be tested for nitrate, bacteria, major ions and trace metals. See Figure 10 for Water Quality Testing Procedure.
- 2. ESTIMATE COSTS** – Get at least three quotes on treatment equipment required based on your raw water quality keeping in mind initial costs, maintenance and effectiveness. Review warranties and call references. Request a repeat test of water quality post-treatment to confirm it is safe to consume and product works.
- 3. MONITORING** – Continue to monitor your water source at least twice per year for nitrate and bacteria; periodically test water after treatment for parameters of concern to ensure treatment is effective. Depending on initial results for major ions and metals they can be tested less frequently. Test your water after major rain events, flooding, or when changes are noticed.
- 4. MAINTAIN EQUIPMENT** – Maintain treatment equipment and equipment associated with the water source (e.g., filters, chemicals, well casing, well cap, pump, distribution, cistern, etc.).
- 5. SHOCK CHLORINATE and DISINFECT** – Shock chlorinate wells twice a year to kill bacteria in the well and out into the aquifer and disinfect your distribution system and cisterns regularly using standard procedures (see Chapter 4 – Well Maintenance and Appendix C –Shock Chlorination and Disinfection). Shock chlorinate and re-test if you receive notification of bacteria in your well.
- 6. KEEP RECORDS** – Keep a record of all monitoring, results, maintenance, and details of the water source and associated equipment. The Well Owner’s Checklist and Record Sheet to document well management (Appendix G – Well Maintenance Schedule).

## Preventing and Troubleshooting Aesthetic Water Quality Problems

Once you have tested your water source and understand the results, it is important to consider other factors that influence the water prior to use including distribution, storage, treatment and land use. For example, hauling water from a treated municipal source and storing it in a cistern can result in contamination during transport or storage. Table 5 identifies factors that can influence your source water quality and how to mitigate the potential for contamination.

**Aesthetic** water quality issues generally impact water use rather than safety. Water that smells or looks bad can prevent people from using it within the household or consuming it even when it is safe to drink. Common complaints include poor taste, smell and colour, and issues with corrosion of taps and fixtures or staining in the kitchen, bathroom and laundry. Improving the aesthetics of the water can increase consumption and decrease costs associated with maintenance of equipment or fixtures within the home. Table 5 and 6 identify some factors that can influence your water quality and practical ways to reduce the potential for contamination or practical solutions to aesthetic issues. Figure 10 can be used as a treatment guide to address aesthetic issues, especially when discussing treatment options with a professional.

**Biofouling** is the growth and deposition of living organisms (e.g., microorganisms) over the surfaces within water systems including the well, plumbing, and treatment or conditioning systems.

**Table 6. Solution to common household aesthetic water quality problems.**

Symptom	Problem	Solution
Change in taste, smell, colour or clarity of the water	Biofouling	<ul style="list-style-type: none"> <li>Disinfection and testing.</li> </ul>
	Surface water influence	<ul style="list-style-type: none"> <li>Protect source water.</li> <li>Perform well maintenance (extend well casing, dyke around the well, ensure cracks and holes in casing are repaired, and install a water-tight cap that can be secured with a lock).</li> <li>Shock chlorination and testing.</li> </ul>
Mineral/chemical deposition or flaking that is white, black or red/brown in colour	Biofouling	<ul style="list-style-type: none"> <li>Disinfection and testing.</li> </ul>
	Mineral and chemical deposits (e.g., calcium, magnesium, sulfate, iron or manganese).	<ul style="list-style-type: none"> <li>Prevent biofouling.</li> <li>Reduce aeration in the well.</li> <li>Reduce cascading water by keeping water levels above the depth of the well screen.</li> <li>Reduce pumping rate to encourage equal flow through the distribution.</li> </ul>
	Corrosion	<ul style="list-style-type: none"> <li>Prevent biofouling.</li> <li>Drilling contractor to determine source or correct the problem.</li> </ul>
Mud or silt in the water or reduced volume	Screen plugged	<ul style="list-style-type: none"> <li>Drilling contractor to clean screen.</li> </ul>
	Aquifer depletion associated with periods of drought that results in decreased well water levels when well is not in use.	<ul style="list-style-type: none"> <li>Reduce water use.</li> <li>Increase recharge time between pumping.</li> </ul>
	Structural failure of the well screen or casing.	<ul style="list-style-type: none"> <li>Drilling contractor consultation to determine if repairs or a new well is required.</li> </ul>
Bubbles, cloudy water or spurting taps	Over-pumping the well	<ul style="list-style-type: none"> <li>Reduce the pumping rate compared to the rate recommended by the driller or driller report.</li> <li>Read pump manual to troubleshoot equipment.</li> </ul>
	Pump not submerged	<ul style="list-style-type: none"> <li>Check that the pump is sufficiently submerged under the water to eliminate air intake.</li> </ul>
	Dissolved gases in well water	<ul style="list-style-type: none"> <li>If reducing the pumping rate and submerging the pump does not work then contact drilling contractor to determine the source.</li> </ul>
Smells like rotten eggs*	Biofouling associated with bacteria that thrive in the presence of iron or manganese produce small concentrations of gas that can build up and be released when you turn on the tap but do not pose a risk to human health. It may also be more prominent coming from the hot water tap.	<ul style="list-style-type: none"> <li>Regular disinfection (including hot water heater).</li> </ul>

**\*CAUTION\***

**If the smell of rotten eggs or the appearance of gas is persistent at the well head and at the tap, it could be an indication of higher concentrations of hydrogen sulfide gas. Contact a qualified service provider if you suspect gas in your well.**

## Aesthetic Water Quality Problems and Treatment

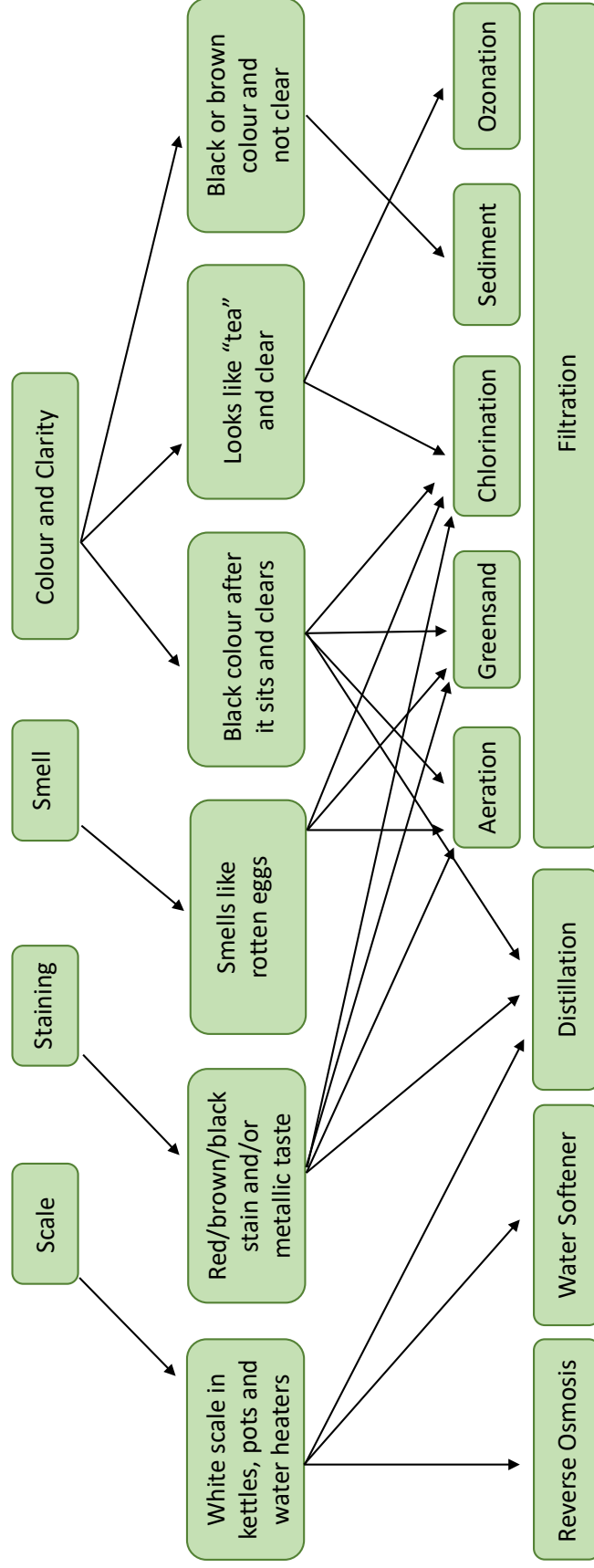

Figure 10. Treatment options for aesthetic water quality issues. Adapted from Health Canada: *What's in your well? – a guide to well water treatment and maintenance.*

# Chapter 4: Source Water Management

Protecting source water is the first step in the multi-barrier approach to managing water. Protecting groundwater through best practices is more cost effective than attempting to treat the water or establish another source once the well is contaminated. **Source water protection** refers to the activities and regulations put in place by individuals and governments to protect water sources from contamination and to ensure their sustainable use into the future. In Saskatchewan, the Water Security Agency has a role in source water protection as outlined in the Acts and Regulations listed in Appendix A - Legislation.

A private well owner is responsible to ensure source water protection through best local land use practices and well maintenance to protect the well and aquifer from contamination. For additional information and assessment on Beneficial Management Practices and grant programs, contact the Ministry of Agriculture through the Agriculture Knowledge Center at 1.866.457.2377 or visit [Environmental Farm Plans](#) on [www.Saskatchewan.ca](http://www.Saskatchewan.ca).

## Source Water Protection

Protection of groundwater sources depends generally on protection of the aquifer through best land use practices and protection of the well itself from contamination. Well and aquifer contamination can make the water unsafe for human or animal consumption and limit the long-term sustainable use of the water source. It can be difficult, expensive or impossible to remediate an aquifer once polluted. Alternate aquifers may not be available or be too costly to drill into. A contaminated aquifer could affect the water quality of nearby lakes, wetlands, streams, dugouts or other wells depending on groundwater movement.

## Aquifer Protection

Aquifer susceptibility to contamination depends on the aquifer depth, soil profile and land use practices. Certain contaminants or pollution can easily move through the soil and media while others do not. Generally, it takes a long time for water and contaminants to move through the soil and into the aquifer. Sometimes taking years, slow moving groundwater can make it difficult to see the effects of contamination until it is too late. It is always a good to apply best land use practices to decrease the potential for contamination because cleanup of groundwater contamination can be time consuming and expensive, if it is even possible.

A shallow aquifer overlain with coarse materials allows for surface water to move easily down into the aquifer, making shallow aquifers susceptible to contamination.

Individuals can protect their groundwater by ensuring potential contamination sources are properly managed and are located a reasonable distance from the well or other water sources. Potential sources of contamination, description and the regulations for proper management are referenced in Table 7.

**Table 7. Setback distances for potential sources of groundwater contamination.**

Contamination Source	Description	Regulations	Management
<b>Onsite Wastewater Systems</b>	<ul style="list-style-type: none"> <li>• Holding/septic tanks</li> <li>• Chambers</li> <li>• Absorption fields</li> <li>• Mounds</li> <li>• Jet disposal</li> <li>• Lagoons</li> <li>• Package treatments</li> </ul>	<p><i>The Private Sewage Works Regulations (2011) and The Plumbing Code Regulations.</i></p> <ul style="list-style-type: none"> <li>• Require a permit</li> <li>• Require a certified installer</li> <li>• The Saskatchewan Ministry of Health <i>Private Sewage Works Regulations</i> provide guidance on well setback distances from non-municipal wastewater disposal &lt; 18 m<sup>3</sup>/day.</li> <li>• The Saskatchewan <a href="#">Onsite Wastewater Disposal Guide</a> summarizes setback distances for private and municipal waste and domestic wells.</li> </ul>	<p>See Chapter 2 – Table 2 for list of well setback distances from onsite wastewater systems.</p> <p>Ensure proper operation and maintenance of the system.</p> <p>Periodically inspect tanks to ensure they are not cracked or broken and the pump is working.</p>
<b>Fuel Tanks</b>	<ul style="list-style-type: none"> <li>• Above or below ground fuel storage</li> <li>• Portable fuel storage or transportation tanks</li> </ul>	<p>Storage and use of fuel on farms is not regulated. Guidelines for Class “C” sites would suggest fuel storage be 500 m from wells or 250 m if wells are in tight clay. Without regulations, minimum recommendations are at least 100 m between fuel storage and groundwater wells. See: <a href="#">Tools Guides and Resources - Fuel Tanks</a></p> <p>Public fuel services are regulated by <i>The Hazardous Substances and Waste Dangerous Goods Regulations.</i></p>	<p>Ensure tanks, dispensers and storage containers are ULC or CSA approved.</p> <p>Monitor for leaks and be prepared for containment (e.g., dykes around tanks).</p> <p>Report spills to the Spill Control Centre at 1.800.667.7525.</p>
<b>Pesticide Application or Storage</b>	<ul style="list-style-type: none"> <li>• Insecticides</li> <li>• Rodenticides</li> <li>• Fungicides</li> <li>• Herbicides</li> </ul>	<p><i>The Pest Control Products Regulations (2015)</i></p> <p>Storage of pesticides at retail and wholesale locations is regulated by <i>The Hazardous Substances and Waste Dangerous Goods Regulations.</i></p>	<p>Never mix, store or apply pesticides close to groundwater well.</p> <p>Store and dispose of pesticide according to the regulations and dispose of empty containers properly.</p> <p>Report spills to the Spill Control Centre at 1.800.667.7525.</p>
<b>Manure and Fertilizer Application or Storage</b>	<ul style="list-style-type: none"> <li>• Animal waste</li> <li>• Crop Fertilizer</li> </ul>	<p><i>The Agricultural Operations Regulations (1996)</i></p> <p>Follow the <a href="#">Tri-Provincial Manure Application and Use Guidelines</a></p>	<p>Apply minimum effective concentration of fertilizer.</p> <p>Never store and apply fertilizer or manure near a groundwater source.</p> <p>Ensure proper handling and storage to reduce leaks or spills.</p> <p>Report spills to the Spill Control Centre at 1.800.667.7525.</p>
<b>Silage and Farm Waste</b>	<ul style="list-style-type: none"> <li>• Waste feed for Livestock</li> <li>• Dead Livestock</li> <li>• General Waste</li> </ul>	<p><a href="#">Silage Storage Techniques</a></p> <p><a href="#">Mortalities Handling Guide</a></p>	<p>When possible, recycle non-organic materials, and compost organic waste.</p> <p>Dispose of dead animals according to the <a href="#">Mortalities Handling Guide</a>.</p> <p>Store silage and feed to prevent leakage and the contribution of nutrients to surface and groundwater.</p> <p>Take all other materials to a licensed landfill site.</p>

## Well Protection

Well protection is important because the well is the most direct route for contaminants to reach the groundwater. Good well design and construction protect the well and aquifer water quality (Figure 11). Protection of the well should keep surface water, insects and animals out of the well. Table 8 provides a check-list to ensure that a well is physically constructed to protect the groundwater.

**Table 8. Well design and construction check-list for well protection.**

<input type="checkbox"/> Well has an annular seal using a cement or bentonite-based grout
<input type="checkbox"/> Top of the well casing is 0.6 to 0.9 m above ground level
<input type="checkbox"/> The area around the well is built up with clay and sloped away from the well
<input type="checkbox"/> The well has a locked and vented well cap
<input type="checkbox"/> The well is located with sufficient setbacks from sources of contamination or other wells
<input type="checkbox"/> Abandoned wells on the property have been properly decommissioned
<input type="checkbox"/> The well was chlorinated after drilling and/or regular bi-annual disinfection is performed
<input type="checkbox"/> The existing well pit, if present, has been removed and a pitless adapter has been installed
<input type="checkbox"/> Any hydrant, if present, is not located within or directly adjacent to the well

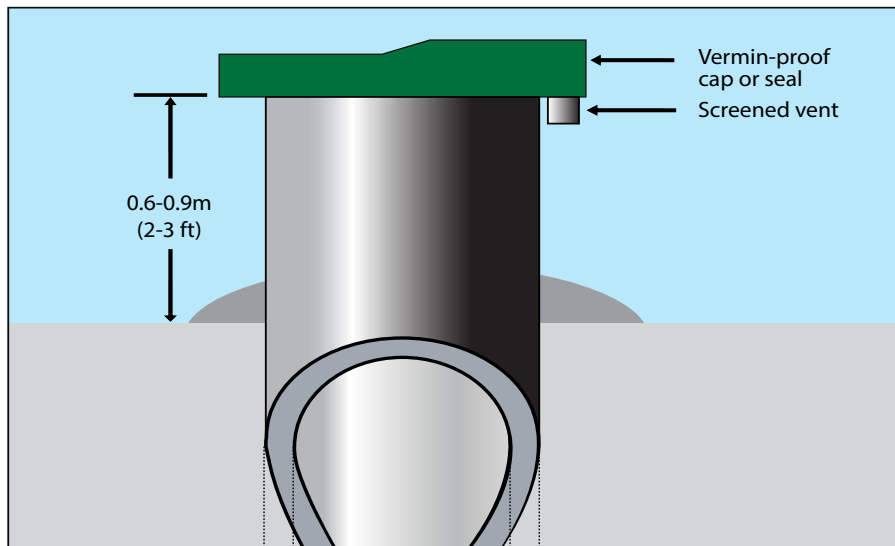

*Figure 11. Well head construction for well protection.*

### **SAFETY MESSAGE**

**WELL PITS may contain dangerous gases or low oxygen levels that pose a significant hazard to human safety. Well pits should be retrofitted with a pitless adapter.**

**Well pits** pose a risk to the aquifer and human safety. In Saskatchewan, older wells may have been completed within a well pit. The well pit is a 2.5 metres to 3.0 metres deep large diameter hole that prevents freezing of the well head and pressure system by ensuring that they are below the frost line. The well pit can collect surface water or shallow groundwater which can seep down the well casing or annulus and contaminate the aquifer. Insects and animals can also make their way into the pit if the cover is not sealed. More importantly, well pits are confined spaces posing a significant risk to human safety through exposure to low oxygen levels or dangerous gases within the pit. Special confined space entry training is required to safely work within a well pit. Well pits should be decommissioned or retrofitted with a casing extension and pitless adaptor.

**Water hydrants** are equipped with a bleeder valve at the base to allow the water to drain back down into the well to prevent freezing within the hydrant itself. A hose attached to a hydrant to fill sprayer tanks or water haulers should not be placed inside the tank because liquid from the tank can be syphoned back into the well. Hydrants should never be completed into, or immediately adjacent to, a well because of increased risk of contaminants moving down into the well. Figure 12 shows incorrect hydrant installation and improper hose positioning.

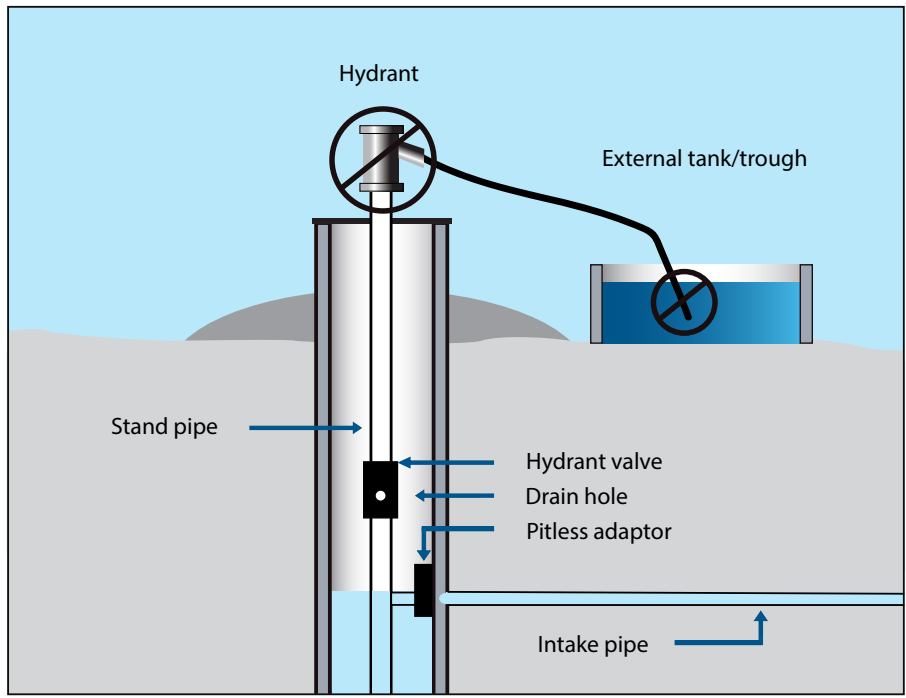

Figure 12. Example of a poor water hydrant installation and hose positioning.

### Well Decommissioning

**Well decommissioning** is the process of taking a well out of service by removing the upper 10 feet of casing and sealing it with bentonite grout so that it no longer presents a physical danger or a potential groundwater contamination source. Abandoned wells or unused wells that are improperly decommissioned pose a serious threat to groundwater quality and can also be a safety hazard. When a well is no longer of use, it should be properly decommissioned. All abandoned wells and test holes should be decommissioned to prevent contamination of the aquifer. Figure 13 shows how an older, abandoned well may influence a nearby well.





## Well Maintenance

Proper well maintenance can extend the life of the well and contribute to the safety of the water for human and animal consumption. Table 9 provides a schedule and list of recommended well maintenance tasks. For regulated groundwater wells, please consult the regulatory agency responsible for additional advice on well maintenance and source inspections. Appendix G – Well Maintenance Schedule provides an example guide to create an individual well maintenance schedule.

**Table 9. Tasks and recommended scheduling for well maintenance.**

Well Maintenance Activity	Description	Schedule
Visual Well and Land Inspection	<ul style="list-style-type: none"> <li>• Check well casing, cap and electrical conduit for wear and holes in the casing.</li> <li>• Ensure ground around the well is sloped away.</li> <li>• Ensure vegetation is physically cleared and large animal access is at least 10 m from the well.</li> </ul>	At least quarterly or more often if required (e.g., vegetation clearing).
Water Levels	<ul style="list-style-type: none"> <li>• Regularly check pumping and non-pumping water levels.</li> </ul>	Check when opening the well for disinfection or other maintenance or at least twice per year.
Well and Water Treatment Equipment	<ul style="list-style-type: none"> <li>• Check any associated storage tanks or cisterns for cracks.</li> <li>• Maintain water treatment equipment according to the manufacturer's instructions.</li> </ul>	At least quarterly or more often if required (e.g., equipment failure, water treatment maintenance).
Well Shock Chlorination	<ul style="list-style-type: none"> <li>• Shock chlorinate to reduce risk of bacterial overgrowth (See procedures in Appendix C – Well Shock Chlorination – high level).</li> </ul>	At least twice per year (spring and fall) or whenever water quality changes (e.g., colour or smell) or the well yield decreases.
Water Quality Testing (Chapter 3)	<ul style="list-style-type: none"> <li>• Test for bacteria and nitrate after shock chlorination to confirm effectiveness.</li> <li>• Test general chemistry, metals, nitrate and bacteria.</li> </ul>	Test bacteria one week after shock chlorination. Test bacteria and nitrate at least twice per year post shock chlorination. Test all parameters prior to establishing treatment or once every five to ten years.

# Appendix A - Legislation

## **The Water Security Agency Act, 2013** – *An Act Respecting Water Rights and the Water Security Agency*

The Water Security Agency was established to manage, administer, develop, control and protect the water, watersheds and related land resources of Saskatchewan. Included in this mandate, the agency has the responsibility for administering the approval process for the construction and operation of water wells and other groundwater works, and the right to use groundwater.

**The Water Security Agency Regulations** – *under The Water Security Act, 2013, The Water Security Agency Act Regulations* give the Water Security Agency the ability to manage well safety and control flowing wells. The regulations also provide the power to implement fees and charges to promote the wise use of water in Saskatchewan.

**The Ground Water Regulations** – *under The Water Security Act, 2013, The Ground Water Regulations* give the Water Security Agency the power to permit for groundwater exploration, register drilling rigs, license drilling and provide guidance on abandoning test holes and wells. The regulations also license groundwater use for non-domestic purposes (e.g., industrial, commercial).

**The Environmental Management and Protection Act, 2010** (EMPA)– *An Act respecting the Management and Protection which repealed The Clean Air Act, The Environmental Management and Protection Act, 2002, The Litter Control Act and The State of the Environment Report Act.*

**The Environmental Management and Protection (General) Regulations** – *under The Environmental Management and Protection Act, 2010, The Environmental Management and Protection (General) Regulations* give the Water Security Agency the power to permit shoreline alterations and discharges of substances at or near water. The Act enables the Water Security Agency to investigate any activities that may pollute the environment, to monitor for effects, to halt such activities and to restore the affected environment. Under the general regulations, the Water Security Agency regulates the activity of liquid domestic waste (sewage) hauling and disposal. The Water Security Agency regulates waste disposal through Permits to Transport and Dispose of Liquid Domestic Waste, which may contain specific conditions for operation.

**The Waterworks and Sewage Works Regulations** – *under The Environmental Management and Protection Act, 2010, The Waterworks and Sewage Works Regulations* are administered under the authority of the Water Security Agency and the Ministry of Environment. Under EMPA, the Water Security Agency can implement the Long-Term Safe Drinking Water Strategy. EMPA provides WSA with clear authority over drinking water quality, provides the ability to regulate waterworks and sewage works, issue protection orders where human health is at risk, issue Precautionary Drinking Water Advisories, collect and manage drinking water quality data, and other aspects of water management.

**The Hazardous Substances and Waste Dangerous Goods Regulations** – *under The Environmental Management and Protection Act, 2010, The Hazardous Substances and Waste Dangerous Goods Regulations* provide clear classification of hazardous substances and waste dangerous goods. It also outlines approvals required for construction and storage of hazardous substances and waste dangerous goods, including transportation requirements under the federal *Transportation of Dangerous Goods Act*.

**The Public Health Act, 1994** – *An act respecting Public Health, The Public Health Act, 1994* gives authority to the Saskatchewan Health Authority for the administration and enforcement of the Act. The act outlines the responsibilities of municipalities to ensure that sewer systems and supply of potable water systems are available to inhabitants of cities, towns, villages and hamlets. The local authority can order the abatement of any condition that is, or may become, a health hazard.

**The Health Hazard Regulations** – *under The Public Health Act, 1994, The Health Hazard Regulations* are administered under the authority of provincial Health Services and the Water Security Agency to regulate semi-public drinking water systems designed to treat < 18 m<sup>3</sup>/day and treated or raw water piped through 3 to 14 service connections.

**The Environmental Assessment Act** – *An act respecting the Assessment of the Impact on the Environment of New Developments, The Environmental Assessment Act* gives authority to the minister, for all matters not assigned to another minister or agency, to plan, assess and make statements on the quality of the environment as it relates to proposed developments.

**The Pest Control Act** – *An act respecting the Control and Destruction of Certain Pests, The Pest Control Act* puts forth rules for the handling, storage and use of pesticides. It includes the following regulations: *The Pests Declaration Regulations, The Bacterial Ring Rot Control Regulations, and The Lake Blight Control Regulations.*

**The Pest Control Products Regulations, 2015 A.K.A. The Pest Control Products (Saskatchewan) Act** – *An act in Saskatchewan according to legislation, The Pest Control Products Regulations, 2015* outline the responsibilities and legal obligations of the minister and provides specific guidelines on the selling, use, application, storage, disposal, cleaning of equipment and licensing of pesticides.

**The Agricultural Operations Act** - *An act respecting agricultural operations, including intensive livestock operations, The Agricultural Operations Act* outlines the legal responsibilities of the minister to support management of animal waste associated with intensive livestock operations.

**The Agricultural Operations Regulations** – *under The Agricultural Operations Act, The Agricultural Operations Regulations* provide instructions on how to apply for approval for intensive livestock operations, and planning, construction and management of animal waste.

# Appendix B - Example of Water Well Driller Report (WWDR)



## Water Well Driller's Report

Page 1 of 1  
25-Jan-2019  
WSaskWWDR01  
(c) Water Security Agency

Well Name: **SASK WATER - MOOSE JAW** Well Owner Name: \_\_\_\_\_ WWDR #: **087410**

Well Location			
Land Location	<b>NE-30-017 -19 -W2</b>	Location of Well (in Quarter)	
LSD	<b>00</b>	0 ft from N/S Boundary	Water Well Driller Report Number (unique)
Reserve		0 ft from E/W Boundary	
RM:	<b>159</b>	Major Basin:	<b>05</b>
NTS Map:	<b>72100</b>	SubBasin:	<b>23</b>
Elevation (ft)	<b>1890</b>	Major Watershed Basin Number	
Aquifer		Watershed Sub Basin Number	

Well Information			
Driller	<b>ANDREWS &amp; SONS DRILLING LTD</b>	Length (ft)	Well Casings
Completion Date	<b>1987.12.16</b>	0	Btm (ft) Dia (in) Material
Hole #	<b>00000001</b>	0	0 4 P.V.C.
Install Method	<b>Drilled</b>	0	0 0
Borehole Depth (ft)	<b>200</b>	Well Screens	
Bit Dia (in)	<b>4.8</b>	Length (ft) Bottom (ft)	Dia (in) Slot (in) Material
Water Level	<b>60</b>	5 111	3 .95 Stainless Steel
Flowing Head	<b>0</b>	0 0	0 0
Water Use	<b>Research</b>	0 0	0 0
Well Use	<b>Observation</b>	Pump Test	
Completion Method	<b>Well Screen And Gravel Pack</b>	Draw Down	<b>19 ft</b>
E-Log	<b>SCANNED</b>	Duration	<b>2 hrs</b>
		Pumping Rate	<b>10 igpm</b>
		Temperature	<b>0 deg. F</b>
		Rec. Pumping Rate	<b>0 igpm</b>

Lithology List		
Depth (ft):	Material	Description
30	Clay	Brown Silty
58	Till	Grey Silty
60	Clay	Grey Silty
90	Silt	Grey Clayey
103	Clay	Grey Silty
112	Sand	Grey Fine-medium
158	Silt	Grey Silty
178	Silt	
200	Sand	



# Appendix C – Shock Chlorination and Disinfection

## Shock Chlorination – High Level (preferred method)

### Materials Required

- A clean water tank with a holding capacity of at least 1,360 litres (300 gallons);
- Garden hose; and
- Industrial strength chlorine (12 per cent NSF-60 sodium hypochlorite approved for drinking water treatment). See Table 1 to determine the specific volume of sodium hypochlorite required based on well depth and casing to achieve the targeted chlorine concentration of at least 250 milligrams/litre.

### Procedure

1. Follow chlorine manufacturer's instructions for use. Chlorine concentrations at this level are dangerous. Avoid contact with skin and inhaling the fumes and wear protective clothing/eye wear. If your well is in a pit, you must make sure there is proper ventilation during the chlorination procedure. It is recommended that you contract the services of a licensed well driller who has the proper equipment and experience to do the job safely.
2. Ventilate confined spaces, e.g., well pit, crawl space, and all other confined spaces where potentially dangerous levels of vapours may accumulate.
3. Do *not* run chlorinated water through certain types of water treatment equipment (e.g., softeners, carbon filters and reverse osmosis systems). For specific information, contact your equipment dealer or the Water Security Agency.
4. The disinfection treatment will require the well to be taken out of service. Therefore, store enough water to meet all necessary requirements for a minimum 12-hour period.
5. Fill the water tank to a minimum of 1,360 litres (300 gallons) with water from the well.
6. After drawing water from the well, allow the well to recover to its static (non-pumping) level.
7. Slowly add 10 litres of the chlorine solution (12 per cent sodium hypochlorite) to the well through the garden hose extended as far down the well as possible. If a well is slow yielding or tends to pump any sediment, slowly siphon the solution down the well and pump it out very slowly. Over pumping the well may worsen the sediment problem. (Note: you can use more precise volumes of sodium hypochlorite by referencing Table 1).
8. Add the remaining 10 litres of the 12 per cent sodium hypochlorite to the tank of water.
9. Start the pump and bleed air from the pressure tank so chlorinated water fills and sanitizes the tank. Open each tap and allow the water to run through all taps until a smell of chlorine is detected, then turn off the taps.
10. Turn entire system off for at least 12 hours. Chlorine can be very corrosive if left in the water distribution system for an extended period.
11. After at least 12 hours, flush the system by pumping the well water through an outside hose (do not exceed the well pumping rate – over pumping the well may worsen any sediment problem), away from grass, shrubs, trees, and other sensitive plants until the strong smell of chlorine disappears. Make certain that the water does not enter any watercourse. Finally, open the indoor taps until the system is completely flushed. Return the system to normal operation. Please note that chlorine can react with organics or other substances to produce by-products in certain cases; therefore, it is important to flush the well prior to returning it to service.
12. If high level disinfection is being used to eliminate a bacterial problem, verify that the procedure has removed the bacteria by following the steps under Disinfection Verification.

**Disinfection Verification**

Find another water source until water testing verifies bacterial counts are zero, or boil the water for one minute, at a rolling boil, before consuming. This precaution is particularly important for persons who are immunocompromised and if the water is being used for infant feeding (preparing formula, etc.).

**Private water supplies:** it is recommended that a sample be taken five days after treatment and another 12 days after treatment with at least one week of constant use. Two consecutive ‘safe’ test results are required to ensure that the treatment was effective. In general, all private systems should be analyzed at least twice per year or whenever there is reason to believe that the water supply may have become contaminated (e.g., flooding).

**Health regulated public water supplies:** Wells not receiving continuous treatment require a sample taken five days after treatment and another 12 days after treatment with at least one week of constant use. Wells receiving continuous disinfection treatment require at least two consecutive sets of samples. The samples should be taken at least one day after the treatment and one day apart. Regional Saskatchewan Health Authority (SHA) officials will be advising the owner/operator of the supply on number of samples, sampling locations and when the water supply can be used again for human consumption. Health regulated public water supplies must sample as required by SHA. If high level disinfection fails to correct the problem in a health regulated public water supply, contact your regional SHA Public Health Inspector for further assistance.

The instructions for shock chlorination above provide a fixed amount of sodium hypochlorite to ensure effective decontamination of the well. If a more precise concentration of 12 per cent of sodium hypochlorite is desired, use the table below to calculate the volume of water in the well and add 12 per cent hypochlorite to the well at a rate of 22 mL (0.022 litre) per 10 litre of water in the casing and the water tank.

**Table 1. Well water volume based on well casing diameter and depth of well.**

Casing Diameter (inches)	Casing Diameter (metres)	Water volume (litre/foot of casing)	Water volume (litre/metre of casing)	Water volume (imperial gallons/foot of casing)	Water volume (imperial gallons/metre of casing)
4	0.102	2.5	8.1	0.5	1.8
5	0.127	3.9	12.7	0.8	2.8
6	0.152	5.6	18.2	1.2	4.0
7	0.178	7.6	24.8	1.7	5.5
8	0.203	9.9	32.4	2.2	7.1
24	0.610	89.0	291.9	19.6	64.2
30	0.762	139.0	456.0	30.6	100.3
36	0.914	200.2	656.7	44.0	144.5
40	1.016	247.1	810.7	54.4	178.3

## Well Disinfection – Low Level

### Materials Required

- Industrial strength chlorine (12 per cent NSF-60 sodium hypochlorite approved for drinking water treatment). See Table 1 to determine the specific volume of sodium hypochlorite required based on well depth and casing to achieve the targeted chlorine concentration of at least 250 milligrams/litre.

### Procedure

1. Follow chlorine manufacturer's instructions for use. Chlorine concentrations at this level are dangerous. Avoid contact with skin and inhaling the fumes and wear protective clothing/eye wear. If your well is in a pit, you must make sure there is proper ventilation during the chlorination procedure. It is recommended that you contract the services of a licensed well driller who has the proper equipment and experience to do the job safely.
2. Ventilate confined spaces (e.g., well pit, crawl space and all other confined spaces) where potentially dangerous levels of vapours may accumulate.
3. Do not run chlorinated water through certain types of water treatment equipment (e.g. softeners, carbon filters and reverse osmosis systems). For specific information, contact your equipment dealer or the Saskatchewan Water Security Agency.
4. If a well is slow yielding or tends to pump any sediment, slowly siphon the solution down the well and pump it out very slowly. Over pumping the well may worsen the sediment problem.
5. The disinfection treatment will require the well to be taken out of service. Therefore, store sufficient water to meet all necessary requirements for a minimum 12-hour period.
6. Slowly add the amount of chlorine as indicated in Table 1 directly into the well. Connect a garden hose to a nearby tap and wash down the inside wall of the well. This will ensure thorough mixing of the chlorine and the water throughout the well.
7. Start the pump and bleed air from the pressure tank so chlorinated water fills and sanitizes the tank. Open each tap and allow the water to run through all taps until a smell of chlorine is detected, then turn off the taps. If a strong smell is not detected, add more chlorine to the well and repeat step 7.
8. Allow the water to sit in the system for at least 12 hours. Chlorine can be very corrosive if left in the water distribution system for too long a period.
9. After at least 12 hours, flush the system by pumping the well water through an outside hose, away from grass, shrubs, trees and other sensitive plants until the strong smell of chlorine disappears. Do not exceed the well pumping rate; over-pumping the well may worsen any sediment problem. Make certain that the water does not enter any watercourse. Finally, open the indoor taps until the system is completely flushed. Return the system to normal operation. Please note that chlorine can react with organics or other substances to produce by-products in certain cases; therefore, it is important to flush the well prior to returning it to service.
10. If low level disinfection is being used to eliminate a bacterial problem, verify that the procedure has removed the bacteria by following the steps under Disinfection Verification.

**Table 1. Disinfection of Well Water with 12 Per cent NSF – 60 Sodium Hypochlorite**

Depth of water in well	Volume of 12 per cent Sodium Hypochlorite Added	
	Casing diameter: 13 centimetres or 5 inch (drilled well)	Casing diameter: 75 centimetres or 30 inch (bored well)
1.0 foot or .3 metres	8.0 millilitres	0.3 litres
5.0 feet or 1.5 metres	40.0 millilitres	1.4 litres
10.0 feet or 3.0 metres	80.0 millilitres	2.8 litres
25.0 feet or 7.6 metres	200.0 millilitres	7.0 litres

**Disinfection Verification**

Find another water source until water testing verifies bacterial counts are zero, or boil the water for one minute, at a rolling boil, before consuming. This precaution is particularly important for persons who are immunocompromised and if the water is being used for infant feeding (preparing formula, etc.).

**Private water supplies:** it is recommended that a sample be taken five days after treatment and another 12 days after treatment with at least one week of constant use. Two consecutive ‘safe’ test results are required to ensure that the treatment was effective. In general, all private systems should be analyzed at least once a year or whenever there is reason to believe that the water supply may have become contaminated (e.g., flooding).

**Health regulated semi-public water supplies:** wells not receiving continuous treatment require a sample taken five days after treatment and another 12 days after treatment with at least one week of constant use. Wells receiving continuous disinfection treatment require at least two consecutive sets of samples. The samples should be taken at least one day after the treatment and one day apart. Regional Saskatchewan Health Authority (SHA) officials will advise the owner/operator of the supply on number of samples, sampling locations and when the water supply can be used again for human consumption. Health regulated semi-public water supplies must sample as required by the SHA. If the low-level disinfection procedure does not eliminate the bacterial or aesthetic issues, then shock chlorinate the well.



## Cistern Disinfection

### Materials Required

- A clean water tank with a holding capacity of at least 1,360 litres (300 gallons);
- Hose and pump;
- Garden hose; and
- Industrial strength chlorine (12 per cent NSF-60 sodium hypochlorite) – available from any chemical dealer, water treatment supplier, or dairy supply retailer.

### Procedure

There are three shock chlorination methods, including: Full Storage Facility, Surface Application, and Chlorinate and Fill. For all methods, water treatment devices should be bypassed during the disinfection procedure and the hot water heater (or gas feed) shut off. Wash and pump out the sludge prior to shock chlorination. Never use non-chlorine bleach or scented bleach to disinfect a cistern. The requirements of the various methods are summarized in Table 1.

**Table 1. Methods and requirements of cistern disinfection.**

Method	Chlorine Dosage	Holding Time	Chlorine Residual	Notes
Full storage Facility	10 milligrams/litre	24 hours	10 milligrams/litre	Repeat procedure if residual is less than 10 milligrams/litre; reduce residual prior to using.
Surface application	200 milligrams/litre, add to drains to achieve 10 milligrams/litre when filled	30 minutes	10 milligrams/litre for drains	Remove water from drains and fill with potable water.
Chlorinate and fill	50 milligrams/litre in about 5 per cent of the volume	6 hours, then fill with potable water and hold for another 24 hours	2 milligrams/litre in full facility after holding period	Remove from drains before filling.

*(For more information: American Water Works Association. 2020. Disinfection of Water-Storage Facilities, ANSI/AWWA C652-19)*

### Full Storage Facility

The full storage method involves adding a chlorine solution to the tank and holding for 24 hours. At the end of the 24 hours, the total chlorine residual should be greater than 10 milligrams/litre. If not, add more chlorine and wait another 24 hours. Repeat if necessary. The highly chlorinated water should not be disposed of into surface water, private sewage system or communal sewage system (unless permission of the owner has been obtained). Reference tank and disinfectant volumes necessary to achieve a 10 milligrams/litre concentration of chlorine found in Table 2.

**Table 2. Tank and sodium hypochlorite volumes to conduct full storage cistern disinfection.**

Tank Volume (imperial gallons)	Sodium Hypochlorite 12 per cent (millilitres)	Tank Volume (litres)	Sodium Hypochlorite 12 per cent (millilitres)
100	2.5 tablespoons (37.5)	100	9
500	$\frac{3}{4}$ cup + 1 tablespoons (232.5)	500	42
750	1 $\frac{1}{4}$ cups (312.5)	750	63
1000	1 $\frac{1}{2}$ cups + 1.5 tablespoons (442.5)	1000	84

**Surface Application**

The surface application method requires that a 200 milligrams/litre chlorine solution is sprayed on all exposed surfaces. To prepare a 200 milligrams/litre chlorine solution pour 30 millilitres of NSF-60 Sodium Hypochlorite (which contains approximately 12 per cent chlorine) into 18 litres (4 gallons) of water. Tank drains are filled with enough chlorine to ensure that when the drain is filled with water, the chlorine concentration is at least 10 milligrams/litre. After 30 minutes, rinse the tank. The highly chlorinated water should not be disposed of into surface water, private sewage system or communal sewage system (unless permission of the owner has been obtained). All confined space entry requirements and other occupational health and safety concerns should be examined before applying chlorine in a confined space. Proper ventilation and breathing equipment should be utilized.

**Chlorinate and Fill**

The chlorinate and fill method involves adding clean water to the tank until it is 5 per cent full (1/20th) and then adding enough chlorine to create a chlorine concentration of 50 milligrams/litre. Let the solution sit for 6 hours and then fill the tank with water. Let this water sit for 24 more hours. At the end of the 24 hours, the chlorine residual should be greater than 2 milligrams/litre. If not, add more chlorine to a concentration of at least 2.5 milligrams/litre and wait for an additional 24 hours. Retest the water to ensure that the chlorine residual is greater than 2 milligrams/litre. Repeat until this chlorine residual can be obtained. Reference tank and disinfectant volumes required to achieve 50 milligrams/litre of chlorine in Table 3.

**Table 3. Tank and sodium hypochlorite volumes to conduct chlorinate and fill cistern disinfection.**

Tank Volume (imperial gallons)	Per cent of Tank Volume (imperial gallons)	Sodium Hypochlorite 12 per cent (millilitres)	Tank Volume (litres)	Per cent of Tank Volume (litres)	Sodium Hypochlorite 12 per cent (millilitres)
100	5	2 teaspoons (10)	100	5	2
500	25	3.25 tablespoons (49)	500	25	10.4
750	37.5	1/3 cup (82.5)	750	37.5	16
1000	50	1/3 cup + 1 tablespoon (97.5)	1000	50	21

After the procedure has been completed, the highly chlorinated water in the cistern can be dumped to waste in accordance with safe practices. The cistern should be flushed and re-filled with potable water. Highly chlorinated water is unsafe for drinking, unsuitable for domestic or livestock use, and will cause problems if discarded into septic fields. Furthermore, environmental regulations exist which prohibit the disposal of highly chlorinated water into streams and ditches, in order to protect the environment. If a water cistern is constructed from concrete, it may be desirable to use at least three loads of water prior to drinking the water for aesthetic reasons (i.e., water may have a chalky appearance and a slight cement taste).

# Appendix D – Information and Resources

## Online Resources

1. Provincial Government Water Quality and Information [www.saskatchewan.ca/water-quality-information](http://www.saskatchewan.ca/water-quality-information)
2. Water Security Agency [www.wsask.ca](http://www.wsask.ca)
3. Groundwater Services [www.wsask.ca/Water-Info/Ground-Water](http://www.wsask.ca/Water-Info/Ground-Water)
4. Regulated Drinking Water Quality [www.waterquality.saskatchewan.ca/DrinkingWater](http://www.waterquality.saskatchewan.ca/DrinkingWater)
5. Surface Water Rivers [www.wsask.ca/water-info/surface-water/surface-water-quality-data/](http://www.wsask.ca/water-info/surface-water/surface-water-quality-data/)
6. Water Well Driller Report Database [www.gis.wsask.ca](http://www.gis.wsask.ca)
7. Saskatchewan Groundwater Association Inc. (306.244.7551)
8. Groundwater Information Network – GIN Basic Map Viewer [gin.gw-info.net/service/api\\_ngwds:gin2/en/wmc/standard.html](http://gin.gw-info.net/service/api_ngwds:gin2/en/wmc/standard.html)
9. Agriculture and Agri-Food Canada – Well design and wellhead protection [agriculture.canada.ca/en/agriculture-and-environment/agriculture-and-water/wells-and-groundwater/well-design-and-wellhead-protection](http://agriculture.canada.ca/en/agriculture-and-environment/agriculture-and-water/wells-and-groundwater/well-design-and-wellhead-protection)
10. Saskatchewan Health Authority – health regions by community [www.saskhealthauthority.ca/facilities-locations](http://www.saskhealthauthority.ca/facilities-locations)
11. Saskatchewan Roy Romanow Provincial Laboratory – request bottles and submit water quality samples for analysis [www.saskhealthauthority.ca/facilities-locations/roy-romanov-provincial-laboratory/water-testing-public/how-collect-and-submit](http://www.saskhealthauthority.ca/facilities-locations/roy-romanov-provincial-laboratory/water-testing-public/how-collect-and-submit)
12. Rural Water Quality Information Tool – fill in water quality results and receive a report on the suitability of the raw water for human consumption [www.agric.gov.ab.ca/app84/rwqit](http://www.agric.gov.ab.ca/app84/rwqit)

## Accredited Laboratories

Roy Romanow Provincial Laboratory (RRPL)  
5 Research Dr.  
REGINA SK S4S 0A4  
306.787.3131 ext. 6  
[www.saskhealthauthority.ca](http://www.saskhealthauthority.ca)

For an updated list of accredited labs in Saskatchewan, see: [CALA Directory of Laboratories](#)

## Appendix E - Groundwater Test Suite

Parameter	Units	Objective <sup>1</sup>	Objective Type
Aluminum	mg/L	ng	
Arsenic	µg/L	10	Maximum Acceptable Concentration
Barium	mg/L	1.0	Maximum Acceptable Concentration
Bicarbonate	mg/L	ng	
Boron	mg/L	5	Maximum Acceptable Concentration <sup>2</sup>
Cadmium	mg/L	0.005	Maximum Acceptable Concentration
Calcium	mg/L	ng	
Carbonate	mg/L	ng	
Chloride	mg/L	250	Aesthetic Objective
Chromium	mg/L	0.05	Maximum Acceptable Concentration
Copper	mg/L	2.0	Aesthetic Objective <sup>2</sup>
<i>E. Coli</i>	ct/100 mL	0	Maximum Acceptable Concentration
Fluoride	mg/L	1.5	Maximum Acceptable Concentration
Hydroxide	mg/L	ng	
Iron	mg/L	0.3	Aesthetic Objective
Lead	mg/L	0.01	Maximum Acceptable Concentration
Magnesium	mg/L	200	Aesthetic Objective
Manganese	mg/L	0.12	Maximum Acceptable Concentration <sup>2</sup>
Manganese	mg/L	0.05	Aesthetic Objective
Nitrate as NO <sub>3</sub>	mg/L	45	Maximum Acceptable Concentration
pH	pH units	6.5 to 9.0	Aesthetic Objective
Potassium	mg/L	ng	
Selenium	mg/L	0.5	Maximum Acceptable Concentration

<sup>1</sup> Based upon Saskatchewan's Drinking Water Quality Standards and Objectives

<sup>2</sup> An objective set by Health Canada

mg/L = milligrams per litre; µg/L = micrograms per litre; µS/cm = microsiemens per centimeter; ct/100 mL = count per 100 milliliters;

ng = no guideline set

## Appendix E - Groundwater Test Suite continued

Parameter	Units	Objective <sup>1</sup>	Objective Type
Sodium	mg/L	300	Aesthetic Objective
Specific Conductivity	µs/cm	ng	
Sulphate	mg/L	500	Aesthetic Objective
Total Alkalinity as CaCO <sub>3</sub>	mg/L	500	Aesthetic Objective
Total Coliform Bacteria	ct/100 mL	0	Maximum Acceptable Concentration
Total Dissolved Solids	mg/L	1,500	Aesthetic Objective
Total Hardness as CaCO <sub>3</sub>	mg/L	800	Aesthetic Objective
Uranium	µg/L	20	Maximum Acceptable Concentration
Zinc	mg/L	5.0	Aesthetic Objective

**Maximum Acceptable Concentration (MAC):** Maximum acceptable concentrations have been established for certain substances that are known or suspected to cause adverse effects on health. Each MAC has been derived to safeguard health assuming lifelong consumption of drinking water containing the substance at that concentration.

**Aesthetic Objective (AO):** Aesthetic objectives apply to certain substances or characteristics of drinking water that can affect its acceptance by consumers or interfere with practices for supplying good-quality water. For certain parameters, both AO and health related guidelines (e.g., MAC) have been derived. Where only AO are specified, these values are below those considered to constitute a health hazard.

<sup>1</sup> Based upon Saskatchewan's Drinking Water Quality Standards and Objectives

## Appendix F – Well Decommissioning

All types of water wells can provide a direct pathway for surface water to travel down into the aquifer. When a well is no longer in use (abandoned) and is not being properly maintained, the risk of contamination to groundwater increases. To protect the water supply, eliminate a safety hazard and liability, and protect land values, landowners must **decommission** abandoned wells to protect their water supply from contamination; eliminate the hazard to people animals, people, and property; and protect property values. A decommissioned well refers to a well that has been properly sealed to prevent the vertical movement of water.

Decommissioning a well can be completed following the [Decommissioning Abandoned Water Wells](#) guidelines as provided by the Water Security Agency; however, if the situation is complex or requires different methods or specialized equipment, then the landowner should contact a qualified contractor to carry out the work. A record of well decommissioning should be submitted to the Water Security Agency using the [Well Decommissioning Worksheet](#) provided online.

Worksheets should be submitted to:

Water Security Agency  
111 Fairford Street East  
MOOSE JAW SK S6H 7X9  
or  
[groundwater@wsask.ca](mailto:groundwater@wsask.ca)

Any questions on well decommissioning should be directed to Groundwater Services at 306.694.3980 or [groundwater@wsask.ca](mailto:groundwater@wsask.ca).

## Appendix G – Well Maintenance Schedule

<b>Well Maintenance Record</b>										
<b>Date</b>						Wells should be inspected at least twice per year and can be paired with regular maintenance including shock chlorination/disinfection or water quality monitoring. It is also beneficial to inspect, shock chlorinate and test the well following unusual events such as heavy rain, flooding and spring runoff.				
Instructions: Record the date and check off inspection, chlorination/disinfection and water quality testing that was carried out each year.										
<b>Physical Well Inspection (Minimum 2 X / year or when the well is being maintained)</b>										
<b>Physical Well Inspection</b>						The well head is free of brush, debris and other obstructions				
						There are no cracks or damage to the well casing or space between the casing and the surrounding ground				
						The top of the well casing is 0.6 to 0.9 m above ground level				
						The area around the well is built up with clay and sloped away from the well				
						The well has a locked and vented well cap				
						Check that the well is located with sufficient setbacks from sources of contamination or other wells				
						Check that abandoned wells on the property have been decommissioned				
						Shock chlorinate after drilling and/or ensure regular biannual disinfection or shock chlorination is performed				
						The electrical connections are not damaged and are properly sealed where wires enter the well				
						Ensure hydrant, if present, is not located within or directly adjacent to the well				
<b>Shock Chlorination and Well Disinfection (Minimum Shock Chlorination 2 X / year and disinfect to maintain the well or address aesthetic concerns)</b>										
<b>Well</b>						Shock chlorination	Casing diameter:    inches	Depth of well:    feet	Concentration of sodium hypochlorite:    %	Notes:
						Disinfection	Casing diameter:    inches	Depth of well:    feet	Volume of sodium hypochlorite used:    mL or L	
<b>Cistern</b>						Method used: Full Storage Facility Surface Application Chlorinate and Fill	Tank volume:       gal or L		Concentration of sodium hypochlorite:    %	
									Volume of sodium hypochlorite used:    mL or L	
<b>Water Quality Monitoring (Nitrate and Bacteria 2 X / year; test for metals and general chemistry to support effective water treatment and repeat every 5 to 10 years.</b>										
<b>Nitrate &amp; Bacteria</b>						Parameters: <u>Nitrate</u> <u>Bacteria</u> (Total Coliform Bacteria and <i>E.coli</i> Bacteria)		Date Sampled:	Results:	Notes:
							Lab:			
<b>Full Test Suite</b>						Parameters (add to the above): <u>General Chemistry</u> (bicarbonate, Ca, carbonate, Cl, conductivity, F, Fe, Mg, Mn, NO <sub>3</sub> , pH, K, Na, SO <sub>4</sub> , total alkalinity, total hardness, and TDS) <u>Health and Toxicity</u> (Al, As, Ba, B, Cu, Pb, Se, Zn, Cr, Cd, U)		Date Sampled:	Results:	Notes:
							Lab:			